

# 2022

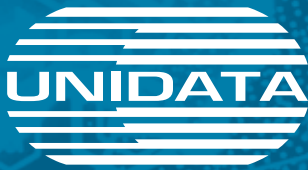

# SUSTAINABILITY

## ESG Report

Individual non-financial statement pursuant  
to Legislative Decree No. 254/2016

[WWW.UNIDATA.IT](http://WWW.UNIDATA.IT)



UNIDATA S.P.A.  
Viale A. G. Eiffel 100  
00148 Roma  
Tax code, VAT number  
and Rome Company Registration  
number 06187081002  
R.E.A. number  
RM-956645  
Share capital  
€ 2.464.642,00 i.v.

“ WE HAVE ALWAYS WORKED WITH THE CERTAINTY THAT KEY OBJECTIVES AND TARGETED CHOICES WERE THE GUARANTEES OF SUCCESS IN THE IMMEDIATE AS WELL AS IN THE MEDIUM AND LONG TERM, AND WE WILL CONTINUE TO THINK SO AND TO DO SO.

**RENATO BRUNETTI** President and CEO of Unidata

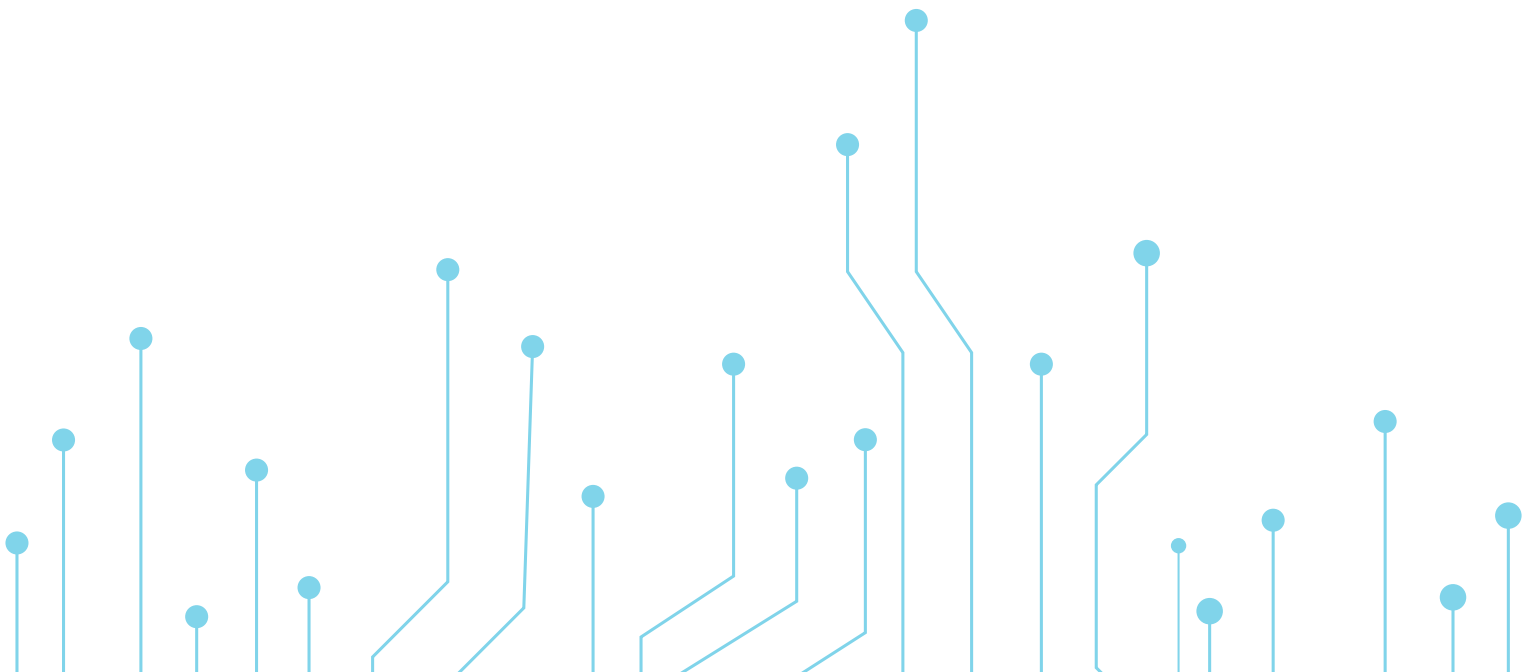



# SUMMARY

7

Letter  
to Stakeholder

9

Methodological  
premise

11

1. Sustainability  
for Unidata

23

2. Society  
and Governance

67

3. The environment

81

4. The social

101

Appendix 1  
Gri Standards

105

Appendix 2  
Index of tables  
and figures

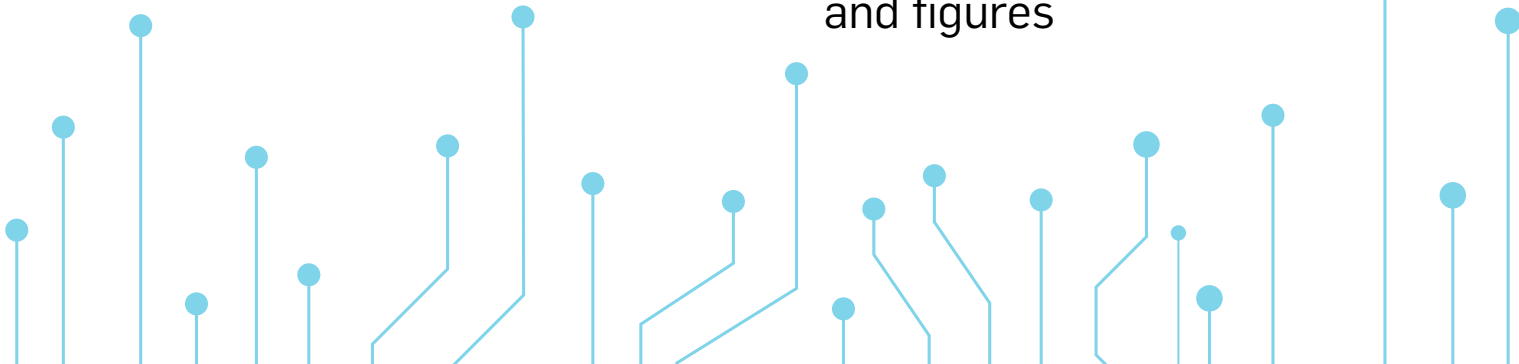



Dear Shareholders and Stakeholders,

2022 was a year of important achievements for Unidata, albeit in a very uncertain context. With the most acute phase of the Covid-19 pandemic behind us, international tensions have put a strain on the economy, with direct repercussions on our priorities and the performance of stock markets worldwide.

Unidata entered its third year since listing, and in such an environment it was able to prove once again in this financial year that its customers and many investors appreciate it.

Once again, this year we have the privilege and good fortune to be able to present significant results, with positive and comforting numbers. The strategic importance of the sector in which Unidata has chosen to operate since the first diffusion of Internet use in our country, and the important and prudent investments made over the years and decades, continue to reward our choices over time.

Many are the initiatives that characterised 2022: from the transformation into a Benefit Company with a shareholders' resolution in spring 2022, to the signing of an investment agreement with the ESG fund managed by Azimut Libera Impresa for the creation of a large Green Data Centre in Rome. Unitirreno was set up for the cabling with submarine fibres for a 900 km section that will connect Mazara del Vallo to Genoa, with outlets to Rome-Fiumicino and Sardinia. We also confirmed and increased, with a general doubling of values, our commitment to the important fibre-optic infrastructural activity, with Fiber To The Home technology, of the so-called grey areas of Lazio and, in perspective, of Central Italy with Unifiber, established together with the international fund CEBF.

The acquisition of Milan Internet Provider TWT represents, as the first M&A transaction in our history, a fundamental step in the growth process that will continue, during the 2023 financial year, with the move from the Euronext Growth Milan market of Borsa Italiana to the regulated market and to its STAR Milan segment.

With this short letter, I have tried to show first the consistency of our path, which is well represented and pondered by the industrial plan approved at the end of November. We have always worked with the certainty that key objectives and targeted choices were the guarantees of success in the immediate as well as in the medium and long term, and we will continue to think so and to do so.

Thanking you for the trust you have placed in us again this year, I wish you good reading.

**Renato Brunetti**

President and CEO of Unidata

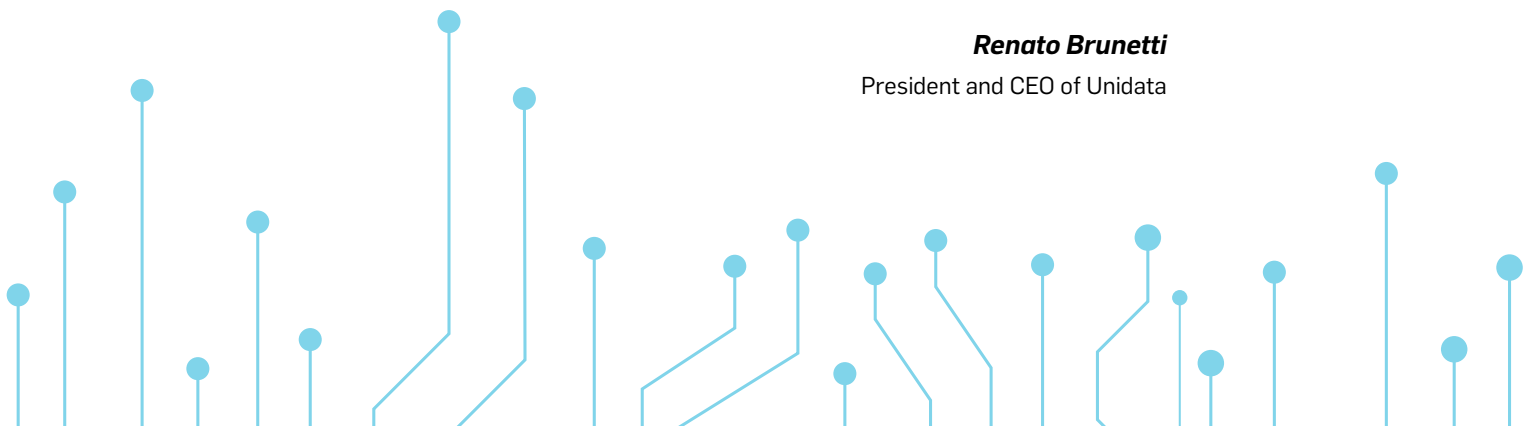





## Methodological premise

In line with the sustainability path undertaken in 2020, Unidata has prepared for the third consecutive year its Individual Non-Financial Statement (hereinafter also DNF or, informally, Sustainability Report), following Articles 3 and 7 of Legislative Decree 254/2016 implementing Directive 2014/95/EU (Non-Financial Reporting Directive), to ensure maximum transparency to the market and its stakeholders. This document refers to the non-financial information relevant to the financial year from 1 January 2022 to 31 December 2022. Data for previous years have been included for comparative purposes to provide an analysis of the company's business performance.

This document aims to offer a representation of the company's activities and results from a different perspective than the purely economic one, highlighting Unidata's concern for the environment, people, and the community.

Starting from the materiality matrix - a fundamental tool for Unidata that represents the overall view of internal and external stakeholders concerning the issues identified in the materiality analysis - this document analyses and highlights the E-S-G (Environment, Social, and Governance) areas and the impacts produced concerning the issues identified as material for Unidata.

In keeping with this premise, Unidata has based its non-financial reporting strategy on the following pillars to ensure an all-inclusive representation of the company's sustainability performance. (For more details see Table 3 - ESG risks on page 13)

- **ESG areas:** each chapter of the DNF addresses each of the material issues associated with ESG areas, which are strongly linked to the Sustainable Development Goals (SDGs);
- **Non-financial risks:** risks that are related to sustainability issues and considered material to society have been mapped out, as well as how these risks are managed;
- **Commitments:** the SDGs, shared by Unidata, on which we believe we can make a greater contribution by defining long-term commitments, have been reported.

This report has been prepared by the GRI Standards (2016): Core option, of the Global Reporting Initiative. In line with the reporting practices described, a table including the topics analyzed about the topics defined by GRI can be found in the appendix of this document. In consideration of the voluntary nature of the adoption of this DNF and since the size parameters outlined in Article 7 of Legislative Decree 254/16 were not exceeded, the Company decided not to subject this document to the attestation of conformity by an independent auditing firm.

The document was submitted to the examination, evaluation, and approval of the Board of Directors of Unidata S.p.A. on 14/03/2023, which declares that the information contained in this Individual Declaration of Non-Financial Nature complies with the provisions of Article 3 of Legislative Decree 254/16.



# SUSTAINABILITY FOR UNIDATA

1.1 Unidata's approach	13
1.2 Unidata Benefit Company	14
1.3 Brand Reputation	15
1.4 The Stakeholders	17
1.5 The Sustainable Development Goals (SDGs)	18
1.6 The materiality analysis	19

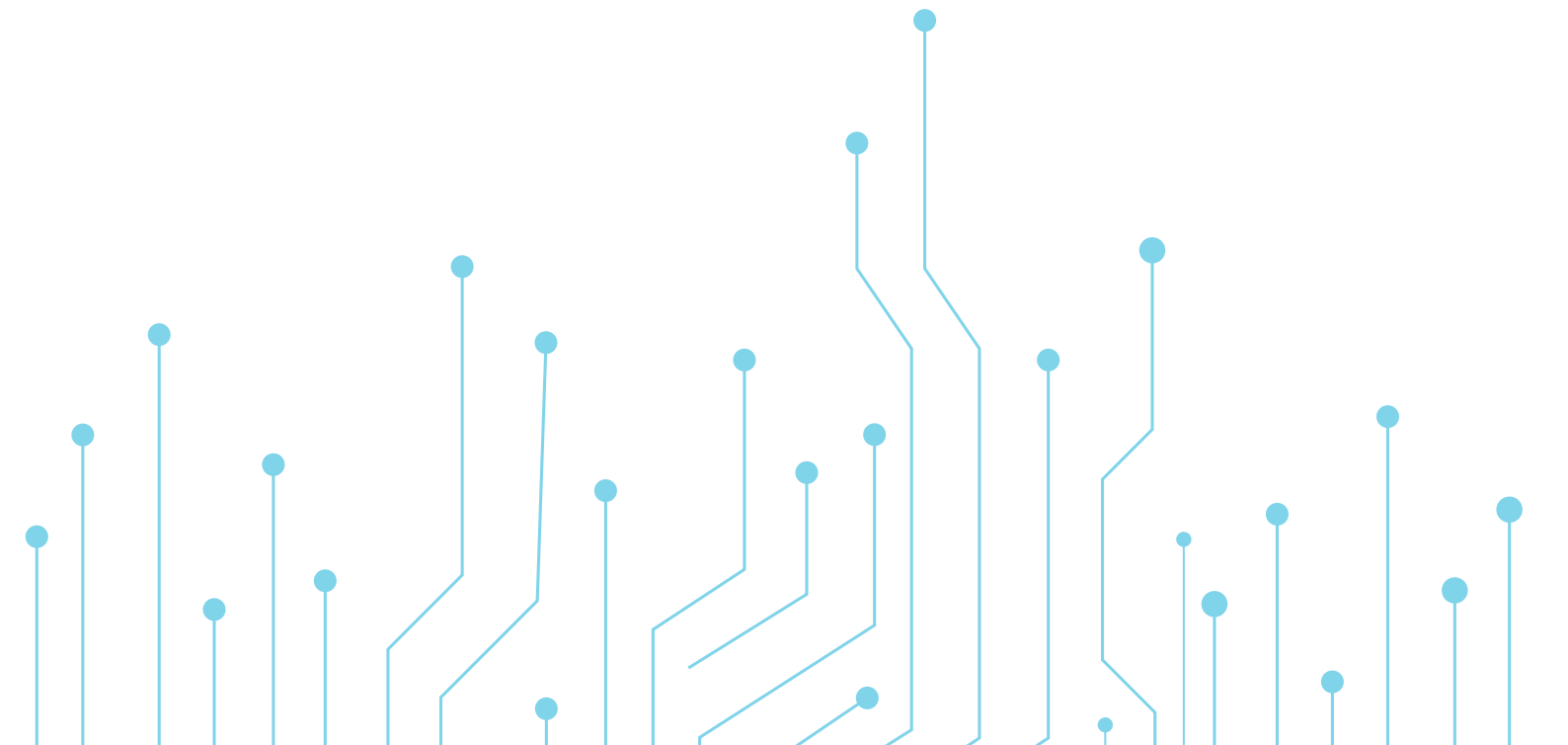



## 1.1 Unidata's approach

Unidata's approach to sustainability is oriented toward the adoption of a new model of sustainable development, based on digital technologies, that embraces the principles of ethical business while respecting people and the environment. As a socially responsible company, Unidata is aware that the transition is only possible through constant involvement and close collaboration with its stakeholders. ESG factors are, in fact, already an integral part of Unidata's growth and development strategies and three-year business plan. Unidata intends to meet the challenges of reducing emissions through energy efficiency, sustainable development of infrastructures, and the valorization of resources, through the Digital Agenda 2030.

Placing the concept of social responsibility at the center of its operations, in 2022 Unidata finalized the process of becoming a benefit company, incorporating in its Articles of Association the commitment to pursue aims of common benefit. This milestone represents an important step in the sustainable development model adopted by the company, which will enable Unidata to make a positive impact concretely. The process of transformation into a benefit company and the consequent implications are set out in more detail in section 1.2.

### Unidata and the National Recovery and Resilience Plan (NRRP)

Digital transformation is a central theme of social and economic development both nationally and internationally. On the subject of digital transformation, the Digital Economy and Society Index (Desi) - which annually summarizes indicators on Europe's digital

performance and tracks the progress of EU countries - places our country in 18th place among the 27 EU Member States for the 2022 edition, up from 20th place the previous year. Although Italy has substantially improved its scores in recent years, in particular thanks to the establishment of a Ministry for Technological Innovation and Digital Transition, our country is called upon to adopt key strategies and launch strategic measures to help accelerate the digitization process.

Italy is making progress in terms of both coverage and diffusion of connectivity networks and is witnessing a significant increase in the deployment of services offering connection speeds of at least 1 Gbps.

The analysis of the Italian results highlights, with lights and shadows, some key points:

- More than half of Italian citizens do not even have basic digital skills, which does not allow them to close the gap with the European average;
- About connectivity, progress is being made in terms of the deployment of broadband services and network implementation;
- 60 percent of Italian SMEs have reached at least a basic level of digital intensity and the use of cloud services, in particular, has grown considerably;
- The use of public digital services has grown considerably in the last two years, even though only 40% of Italian internet users use them, compared to the EU average of 65%.

Unidata, in this regard, has decided to contribute to the national digital transformation by signing, in April 2022, an

agreement with CNA Rome to implement innovative Digital Transformation projects. The parties will develop initiatives to create a synergy between the digital projects promoted by CNA Rome and the innovation of UNIDATA's technologies, to provide member companies with an integrated approach capable of combining business sector knowledge and technological expertise. Unidata will provide Smart Technology on GPON fibre, evolved Virtual Switchboard solutions, Video Conference solutions for Smart Working and Teleworking.

This new model of Digital Transformation represents an opportunity for companies to grow; understand customers' needs, improve employees' work experience, be timelier in developing new products and services, create new partnerships, and invest in cutting-edge projects.

## 1.2 Unidata Benefit Company

By choosing to become a Benefit Corporation in May 2022, Unidata has made it clear that its vision insists on an integrated strategic approach to business that is already the company's own: concern for the community, proximity to all collaborators, mitigation of polluting factors, judicious choice of suppliers and inclusion policies dictated by a sense of responsibility that Unidata's management has uninterruptedly demonstrated in almost forty years of activity.

The 2016 Stability Law introduced into the Italian legal system a new discipline aimed at promoting the establishment and dissemination of Benefit Societies. The latter integrates into their corporate purpose, in addition to profit objectives, the need to have a positive

Unidata is also a founding member of the newly established Rome Technopole Foundation, supporting it in its projects in line with the three strategic axes of the National Recovery and Resilience Plan shared at the European level: digitalization and innovation, ecological transition, and social inclusion.

The Rome Technopole Foundation - an organization in which the most important universities and public institutions in the Lazio region, as well as leading private entities in the country, participate - is committed to disseminating the culture of 'innovation ecosystems', financed by the European Union with Next Generation EU funds, as part of Mission 4 (Education and Research), component 2 ('from research to enterprise') of the National Recovery and Resilience Plan (PNRR).

GRI 102-10 102-16

impact on society by creating a high social value while respecting the environment and future generations.

To meet the transparency requirements of the legislation, Benefit Societies are required to prepare an annual impact report to be attached to the financial statements and published on the company website.

In fulfilling its obligations, Unidata has included three specific purposes of common benefit in its statutes. For more details, please refer to the full document; the three pillars identified by Unidata are briefly mentioned below:

1. To promote the right of all people to be connected as a lever of social inclusion



by spreading the widest possible access to connectivity and digital services throughout the territory. Research, develop, and promote increasingly high-performance solutions as a means of improving people's lives and business productivity;

2. Promoting employee and collaborator satisfaction through training opportunities for personal and professional development and favorable conditions for work flexibility;
3. Implement a gradual evolution of its business and operating model towards a

### 1.3 Brand Reputation

Throughout its 38-year history, Unidata has consolidated a perception of trust and reliability, combined with technical expertise and an eye for innovation, which has always allowed it to grow, albeit in a highly competitive environment, characterized by the presence of much larger players and a dynamism linked to the structuring of increasingly challenging offers and solutions.

climate-neutral economy, in line with European climate neutrality objectives and national ecological transition objectives, also by adopting policies for the responsible use of natural resources through the reduction of pollution and consumption;

Unidata intends to pursue these aims in the exercise of its business activities, generating a measurable positive impact on society and the environment on the one hand, and satisfactory economic results on the other.

The company, founded in 1985 by three professional technicians, has for this reason a 'DNA' characterized by the values of technological competence, up-to-dateness, and the ability to anticipate innovative solutions related, over the decades, to micro informatics, network systems, servers and then telephony in VoIP and increasingly advanced infrastructure solutions up to fibre

optics for Internet access, Cloud solutions and the Internet of Things.

Unidata, today an Internet Service Provider, was in fact born well before the Internet and the World Wide Web characterized solutions and lifestyles throughout the world. This anticipation is itself a demonstration of how Unidata can represent, at the same time, a perpetual start-up, but also an 'ancient' reality, which the Internet can be said to have seen come into being and take its first, timid, steps.

### **TWT acquisition, partnership, Italian Stock Exchange**

Over the years, Unidata was initially able to boast an excellent reputation in the business sphere, being at that time a B2B only, focused on the Rome area. Today, and in particular following the opening of an office in Bari (2022), the acquisition of the Milanese telecommunications company **TWT** (announced in 2022 with closing in February 2023) and important partnerships (above all the one with the large wholesale-only operator **Open Fiber**) Unidata is now among the operators of national importance with an opening to the B2C world; all reinforced, of course, by the listing on the AIM Italia market (now EGM) of the Italian Stock Exchange, which took place in March 2020: the first step towards listing on the main market, in the STAR Milan segment, scheduled for 2023.

Another significant aspect in terms of brand valuation is the performance of Unidata's share price. In fact, despite the particularly critical situation for the global economy and the world's stock markets for geopolitical reasons known to all, during the 2022 financial year the share price showed substantial stability.

### **Obtaining SOA certification**

In November 2022, Unidata obtained the SOA certificate of qualification for the

OS19 category for companies operating in the 'Telecommunication network and transmission and processing equipment' sector.

The SOA certificate, which is compulsory for participation in public tenders, is valid for five years and is issued by SOAs (Società Organismi di Attestazione) authorised by ANAC (National Anti-Corruption Authority) and **recognises the quality of the activity performed by Unidata**, in terms of technical, economic and organisational capacity, **to execute public works** with amounts exceeding € 15,494,000, i.e., corresponding to the 8th classification, **the highest one envisaged**. In addition, the certificate includes qualification for design and construction services up to Classification V, i.e., for amounts up to € 5,165,000.

### **Presence and visibility in the press and recognition among Growth Leaders**

In the wake of the *price-sensitive* announcements related to the compulsory and voluntary disclosures linked to the listing on the Stock Exchange, Unidata's 'name' has, over the last two and a half years, also found greater circulation in the most important editorial offices of nationally important print and online newspapers (Il Sole 24 Ore, La Repubblica, Il Corriere della Sera, Milano Finanza, Il Messaggero, Ansa, Adnkronos, to name but a few). This made it necessary to create two separate sections of the Company's website, one dedicated solely to financial press releases, and another to *corporate* press releases, with related press review pages: pages updated, to date, very frequently, close to daily.

The aforementioned recognition by major newspapers and magazines also led to Unidata's inclusion among the **Growth Leader** companies: in the report compiled by Sole 24 Ore and Statista, Unidata was in



fact selected among the Italian companies that had the most significant and fastest **growth in turnover** in the three-year 2018-2021, entering the *ranking* for the important contribution and support provided to the Italian market. Here are the reasons that led to the prestigious recognition:

*“Unidata’s contribution to the country’s economy has been made possible thanks to the objectives achieved on several levels, including*

*the projects to extend its FTTH Optical Fibre network in the grey areas of Lazio - under an investment agreement with CEBF (Connecting Europe Broadband Fund) - through the newly established company Unifiber; admission to the Euronext Growth Milan market (formerly AIM) of the Italian Stock Exchange; the design of a new Data Centre; and the IoT solutions implemented in the Smart Water Metering area with the LoRaWAN® network.”*

GRI 102-21 102-40

## 1.4 The Stakeholders

The Global Reporting Initiative describes stakeholders as parties or individuals who can reasonably be expected to be significantly affected by the organisation’s activities, products or services, or whose actions may affect the organisation’s ability to implement its strategies or achieve its objectives.

Unidata recognises the importance of stakeholder engagement activities. Consequently, it is committed to taking on board the perspectives and priorities of its stakeholders, integrating them,

where possible, in a manner compatible with economic, environmental, and social objectives with the aim of establishing a relationship of trust and transparency.

In the phase following the identification of the material topics contained within this DNF, Unidata surveyed its stakeholders, aimed at assessing the importance of the material topics with respect to their impact on the company. Unidata’s main stakeholders are:



Table 1 – Unidata Stakeholders

## 1.5 The Sustainable Development Goals (SDGs)



Figure 1 - Sustainable Development Goals (SDGs)

Sustainability is not a purely environmental issue. Six years after the signing of the 2030 Agenda, there is growing awareness in civil society, the business world, national government, administrations, and public opinion of the need to take an integrated approach and define concrete measures to address the many complex environmental and institutional challenges.

Also, this year, Unidata renews its involvement in support of some SDG's of the 2030 Agenda for Sustainable Development. In this context, the Sustainable Development Goals have provided excellent insights into corporate sustainability policies.

In line with the activities carried out, the strategic framework and the context in which Unidata operates, the company contributes to the achievement of 13 of the 17 SDGs goals broken down into ESG areas below.



Figure 2 - Unidata's SDGs targets

## 1.6 The materiality analysis

In line with the provisions of Legislative Decree 254/2016, the methodology, and the principles set out in the GRI standards, Unidata carried out an analysis to identify the issues considered 'material' for the company and form a materiality matrix.

**Material issues** are understood as such because they reflect economic, environmental, and social impacts that significantly influence stakeholders' assessments and decisions in the short, medium, or long term. Therefore, materiality analysis is the pivotal process underlying the drafting of the Sustainability Report and the result of this analysis is the fulcrum around which the Non-Financial Statement is developed.

The basic steps for carrying out this analysis consist of a phase of identification of the material issues and a phase of their evaluation with respect to their relevance for Unidata's main stakeholders.

The topic identification phase was carried out considering the main trends in sustainability issues relevant to Unidata, including a benchmark analysis of the main *peers* and **best practices** in the sector. Subsequently, in line with the procedures listed above, a questionnaire was submitted to internal and external stakeholders. The purpose of the latter was to analyse the degree of relevance of the issues identified as

material, considering the business sector and the organisation's operating context.

The results of the analysis conducted are reflected in the materiality matrix, which highlights the most relevant ESG issues for both Unidata and its Stakeholders, on which the contents of this Non-Financial Statement are based. Moreover, the framework provided by this matrix represents an important tool for Unidata to identify the trajectory to be taken to respond to and define strategic priorities in the field of sustainability.

The themes identified are shown in the chart below:

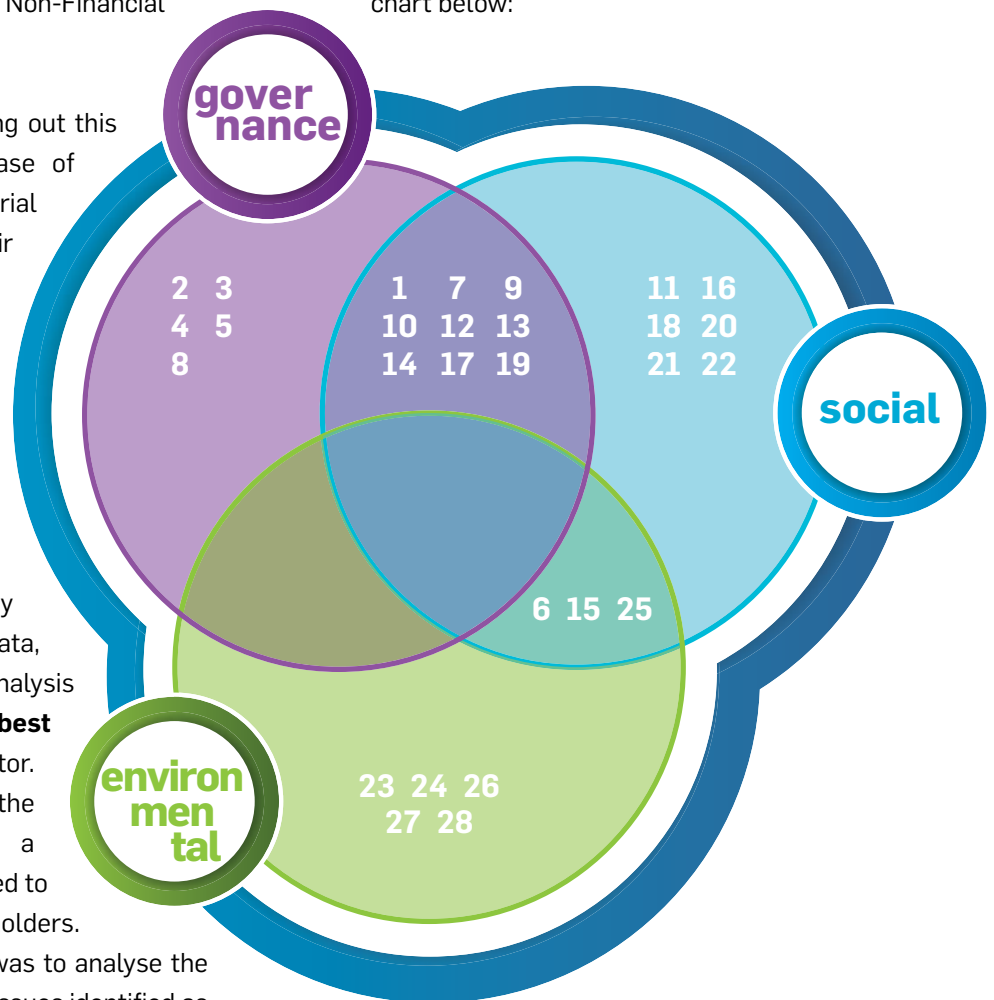

Figure 3 - Material themes for Unidata



**governance**

- 2 Sviluppo dei servizi Data Center e Cloud
- 3 Centralità del cliente
- 4 Governance solida e condotta trasparente
- 5 Risk Management e capacità di reazione ai cambiamenti
- 8 Creazione di valore economico finanziario

**governance social**

- 1 Implementazione della rete in fibra ottica
- 7 Etica ed integrità del business
- 10 Privacy e Cybersecurity
- 12 Formazione e sviluppo delle competenze
- 13 Salute e sicurezza sul lavoro
- 14 Walfare aziendale
- 17 Innovazione del business per il cliente digitale
- 19 Rapporto e dialogo con gli Stakeholder

**social**

- 11 Gestione, sviluppo e motivazione dei collaboratori
- 16 Qualità della customer satisfaction
- 18 Reputazione del Brand
- 20 Supporto e sviluppo alla comunità
- 21 Attrazione di talenti
- 22 Inclusione e diversità

**social environment**

- 6 Integrazione degli aspetti di sostenibilità nella strategia di business
- 15 Catena di fornitura sostenibile
- 25 Soluzioni ICT per lo sviluppo sostenibile

**environment**

- 23 Efficienza energetica
- 24 Decarbonizzazione del Mix Energetico e diffusione delle energie
- 26 Salvaguardia del territorio
- 27 Cambiamento climatico ed emissioni
- 28 Attenzione all'utilizzo delle risorse

Table 2 - ESG Themes

The results of the analysis show a high degree of significance for both internal and external stakeholders with respect to the following issues:

- 

3 Customer centricity
- 

1 Implementation of the fibre optic network
- 

16 Quality of customer satisfaction
- 

18 Brand Reputation
- 

23 Energy efficiency

Below is an analysis of the risks classified according to ESG issues:

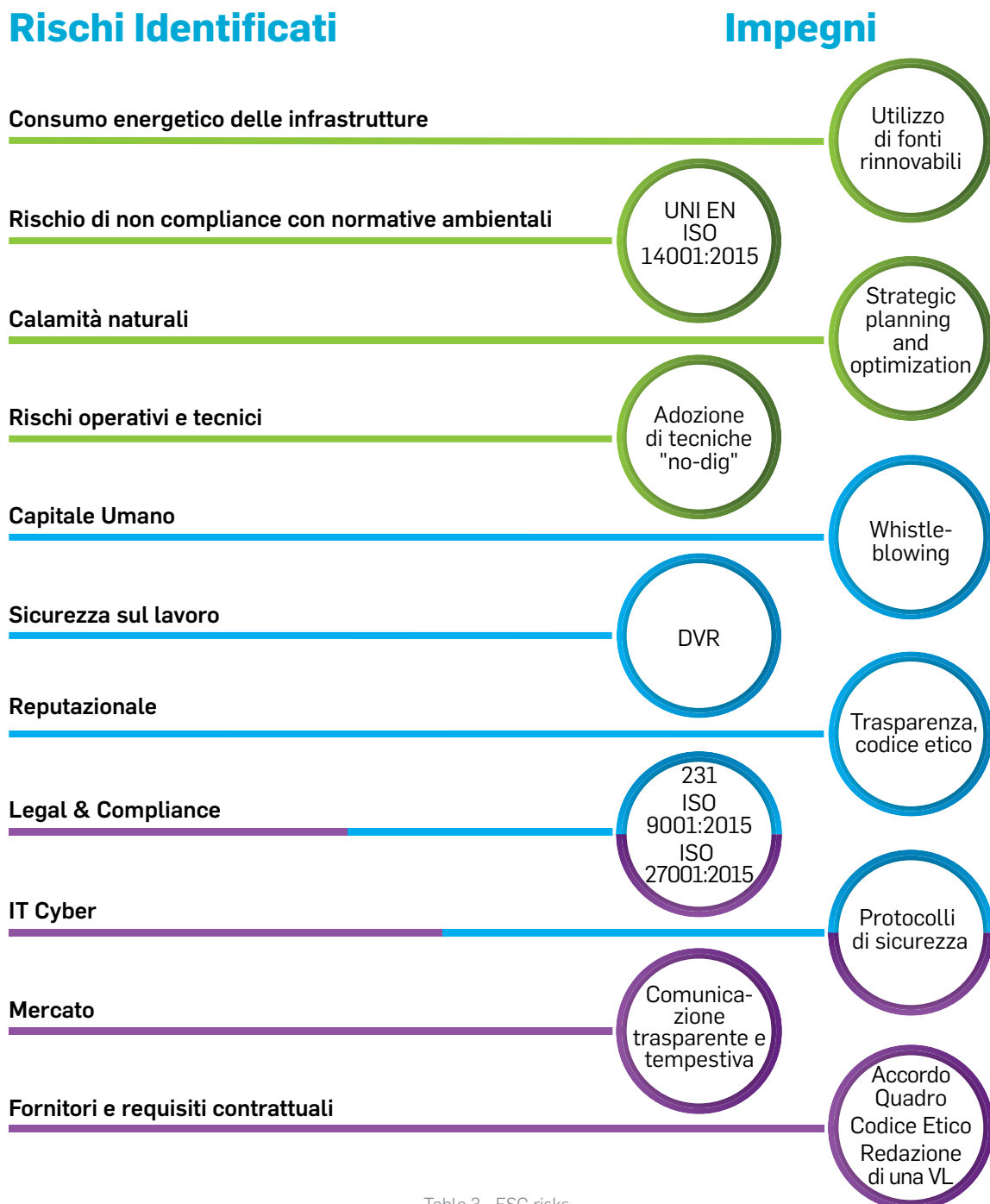
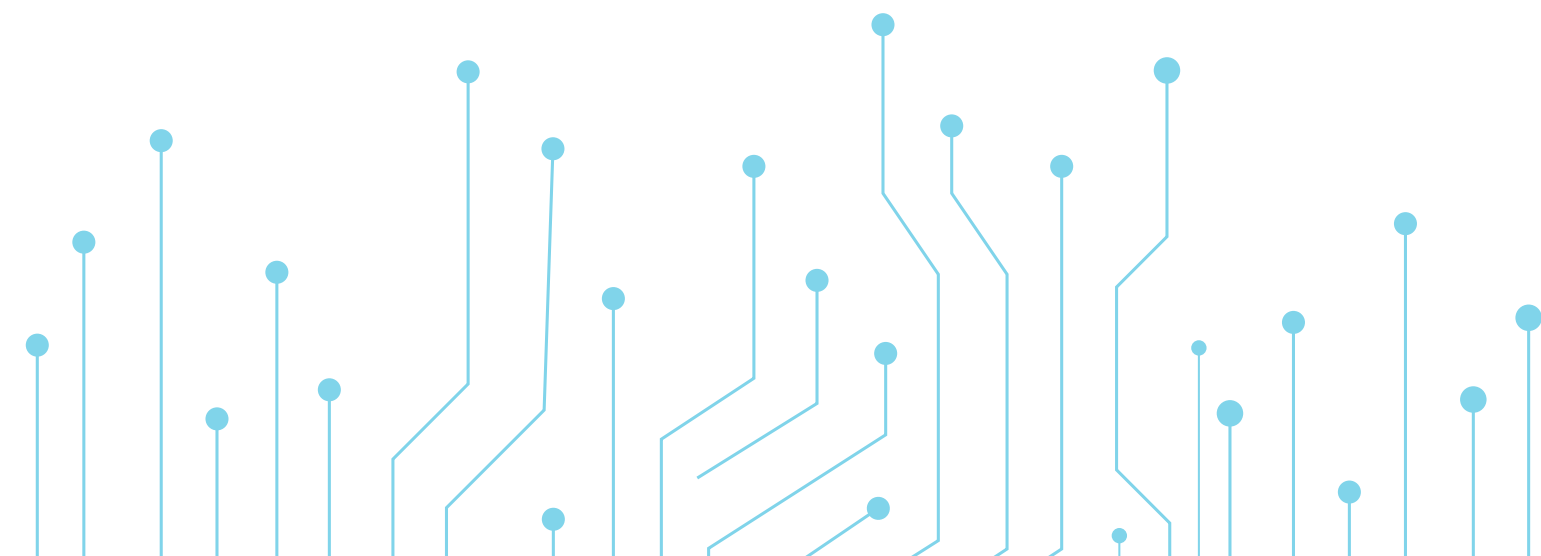

Table 3 - ESG risks



# SOCIETY AND GOVERNANCE

2.1	The History	25
2.2	The Reference context	27
2.3	Corporate Governance	30
2.3.1	The Shareholders' Meeting	32
2.3.2	The Board of Directors	33
2.3.3	The Board of Auditors	34
2.3.4	The Management	35
2.4	Internal Control and Risk Management System	36
2.4.1	The Supervisory Board	36
2.4.2	The Code of Ethics	37
2.4.3	The Enterprise Risk Management	38
2.5	Economic performance and value distribution	46
2.6	Implementation of the Fibre Optic Network	50
2.6.1	Digitising of grey areas	52
2.6.2	Fibre Network Security and Networking	54
2.6.3	The quality of the service	55
2.7	Data Centre and Cloud Services development	56
2.7.1	Data Centre Security	58
2.8	Cybersecurity	61
2.9	Customer focus	63
2.9.1	From customer-oriented to customer-centric company	64







## 2.1 The History

Unidata's history is characterised by distinct phases as can be seen in the table below. Since its inception, the company has always pursued a path oriented towards innovation

and the adoption of the most promising expressions of technological progress in telecommunications.

- 1985

**The foundation**

The history of Unidata began in 1985. The company was a hardware provider, active in the production of PC and server components for the first 14 years.
- 1994

**Development as ISP**

Realising the full potential of the Internet, the company revolutionised its core business and started as an Internet Service Provider.
- 1999

**Sale of the first Unidata**

The British Cable&Wireless group acquired 100 per cent of the company by incorporating it into its Italian branch.
- 2002

**Repurchase of Unidata, development as telco, fibre optic infrastructure**

The founding partners repurchase the company branch from Cable&Wireless with the original name and brand. They start the realisation of the proprietary Fibre Optic infrastructure and the Data Centre, which becomes operational in 2003, representing together with ISP the Telecommunications sector.
- 2017

**Consolidation of connectivity and new certifications**

Unidata is awarded 26 ghz broadband frequencies in the Lazio Region. It extends its activities to the provision of Cloud services and the Internet of Things.
- 2018

**Strategic partnership**

Signing a strategic partnership with a leading telecommunications operator for the development of fibre optic infrastructure.
- 2019

**Hypo process start-up**

Unidata starts the process for admission to the AIM Italia market of Borsa Italiana.
- 2020

**40 and the birth of Unifiber**

On 16 March 2020, Unidata was listed on the AIM Italia market (now EGM) Thanks to an agreement with the international investment fund CEBF, Unifiber S.p.A. Was established on 18 December 2020 to provide fibre optic FTTH cabling in the 'grey areas' of Lazio.
- 2021

**ESG reporting and benefit companies**

Unidata decided to embark on the path towards becoming a Benefit Corporation by enhancing and formalising the sustainability practices already part of the corporate structure.

The year 2022 was therefore a year of change for Unidata from a structural point of view and consolidation of the targets set during the previous year.

In **April 2022**, Unidata became a Benefit Company, taking a further step towards establishing a more sustainable identity that is more attentive to environmental, social and governance aspects. By integrating its bylaws, Unidata has decided to add, in addition to the economic objectives typical of commercial companies, common benefit objectives that mainly concern social and environmental sustainability. In compliance with the relevant regulations, an impact manager has also been appointed to report annually on what the company has done regarding benefit objectives.

On **22 June 2022**, following the letter of intent signed in July 2021, an investment agreement was signed with the Fondo Infrastrutture per la Crescita - ESG managed by Azimut Libera Impresa SGR.

The purpose of the joint venture - which will take place through a special purpose company called **UniCenter** - is to build a *green and neutral* Tier IV level data centre with a pool of national and international customers using renewable energy sources to the maximum extent possible. In this context, UniCenter will operate on a wholesale-only basis, while Unidata will continue to provide services and/or carry out activities in the data centre sector in favour of customers requiring data centre services with a power of less than 30kw.

On **29 September 2022**, Unidata announced that it had reached binding agreements with an infrastructure fund for the construction of a submarine fibre system in the Tyrrhenian Sea. The project will be implemented

through the establishment of a company called UniTirreno.

On the same date, Unidata and the Connecting Europe Broadband Fund or CEBF signed amending and supplementary agreements to provide for the doubling of the investment in **Unifiber**, a company owned 70% by CEBF and 30% by Unidata S.p.A., created to build a fibre-optic network in the grey areas of Lazio.

**25 November 2022** - Unidata announced the signing of a binding contract to acquire the entire share capital of the '**TWT Group**' - consisting of Voisoft s.r.l., Berenix s.r.l. and their subsidiaries.

The TWT Group, founded in 1995 in Milan, is one of the leading players in the field of telecommunications and connection and communication services (so-called "Information and Communication Technologies"), with a particular focus on the B2B segment. In particular, the TWT Group boasts more than 33,000 direct and indirect customers (through accredited resellers), a Tier 3+ data centre located at the Group's headquarters in Milan (approx. 3,400 sq m) and a proprietary fibre optic network (approx. 100 km) in the Milan area.

On the same occasion, the Board of Directors approved the revision of the **2022-2024 Business Plan** with an extension to **2023-2025**, which not only confirms the consolidated growth trend of the last two years, but also takes into account the recently announced major transactions:

- the acquisition of the TWT Group described in detail in the preceding paragraphs;
- the participation in UniCenter for the creation of a Tier IV green data centre in Rome Fiumicino;
- doubling the investment in Unifiber to build a fibre optic network in the grey areas of Lazio;

- the participation in UniTirreno for the construction of a submarine fibre system in the Tyrrhenian Sea.

On **27 December 2022**, Unidata, following the agreement reached on 29 September 2022, announced that it had signed binding agreements with Azimut Libera Impresa SGR's Fondo Infrastrutture per la Crescita

ESG (IPC Fund) for the construction of a submarine fibre system in the Tyrrhenian Sea of approximately 900 kilometres, which will connect Mazara del Vallo with Genoa, with a junction point near Rome-Fiumicino. The project will be implemented, as previously mentioned, through a special purpose company named **UniTirreno Submarine Network S.p.A.**

GRI 308-01

## 2.2 The Reference context

The telecommunications sector is of fundamental importance for the country system, as it generates a turnover of around EUR 71 billion in Italy and contributes 2.3 per cent to the national GDP.

According to the estimate presented in the report 'Operator Revenue Strategies: Business Models, Emerging Technologies & Market Forecasts 2023-2027<sup>1</sup>, prepared by Juniper Research, in fact, Telecom operators are expected to generate USD 625 billion in revenues from 5G services globally by 2027, thus doubling the USD 310 billion turnover forecast for 2023.

Considering this market scenario, Unidata chose to adopt an expansion strategy.

The agreement signed in November 2022 will enable it to create a unique, 100% Italian reality in the world of telecommunications, with a strategic presence throughout the country and on the various sales channels that characterise the Groups core business.

The binding agreement for the acquisition of the entire share capital of the TWT Group will

allow both companies to expand and develop their offer of connectivity services and expand their geographical presence in new markets not covered to date, to achieve synergies and economies of scale.

Unidata will be able to diversify and strengthen its commercial offer, making use of both TWT's sales channel - already present throughout Italy - and TWT's platform dedicated to reseller channel customers, which is of great relevance in the current competitive environment.

This operation will bring significant benefits to both parties involved: Unidata will be able to offer its services throughout Italy using the newly acquired infrastructures, while TWT will have the opportunity to expand its offer of connectivity services, also providing innovative ICT solutions (VoIP solutions, cloud-based services, managed services and housing and hosting services thanks to proprietary data centres).

The acquisition of TWT will represent a further consolidation of Unidata's position as a company committed to ESG issues.

1 - S. Di Palma, 'Telco market in Italy, proposals to relaunch it', La Repubblica, 2022

The Lombardy company, as will be seen in more detail in the chapter on corporate social responsibility, is extensively involved in community-oriented initiatives.

This operation determines the starting point for the creation of shared value through more inclusive models capable of generating positive impacts in social terms.

Continuing in the strategic growth perspective, as mentioned in the previous section (1.6), Unitirreno, a special purpose vehicle (SPV) set up to create a submarine fibre system, was established in December 2022. This operation constitutes another decisive investment for the country's digital transition and its economy that perfectly combines a return in economic-financial terms with positive impacts on the community.

The agreement provides for the construction of a submarine fibre system in the Tyrrhenian Sea of approximately 900 kilometres that will connect Mazara del Vallo to Genoa with a junction point near Rome-Fiumicino. The work will replace the current junction in Marseille and will be a strategic landing point for inter-continental cables from Asia and Africa.

The implementation of the new network will be entrusted to Alcatel Submarine Networks and Elettra Tlc S.p.A.. It will also be the first 24-pair fibre optic Open Cable system in the Mediterranean region using state-of-the-art submarine technology to meet the ever-increasing broadband needs both nationally and internationally. A speed of 20 Tbps (terabytes per second) per fibre pair is planned. This equates to a total system capacity of 480 Tbps on the main route and 320 Tbps on the 16-fibre pair branch to Fiumicino. The new network will also include stubbed branch uni-

ts to facilitate future landings in Sardinia and/or Palermo.

The initiative envisages a total investment estimated at EUR 70 million, of which EUR 36 million will be provided by the shareholders: in particular, Unidata will invest between EUR 12.5 million and EUR 18.5 million.

The submarine fibre-optic market is booming, with global investment projected at USD 2.5 billion between 2022 and 2024. Today, almost all the world's Internet traffic (more than 95 percent) is carried through a global network of more than 400 fibre-optic backbones covering a total distance of 1.3 million kilometers. Investments are needed to support the growing volumes of data and their transmission and connection speed (5G development, iCloud, cybersecurity, audio/visual content, metaverse, augmented reality, telemedicine, smart cities, etc.).

October also saw the inauguration of the new operational and commercial headquarters in Bari, in the industrial area of Modugno.

The new project represents an important growth milestone for Unidata and at the same time an opportunity to establish itself also in Southern Italy, giving rise to future infrastructural potential in the area through a proprietary network. The aim is to create high-tech projects related to the areas of video surveillance, smart cities, and remote control, thanks to the strong and fruitful collaboration established between Unidata and an important local consortium.

By monitoring the technological opportunities of the future and orienting its choices towards

## sustainable models, Unidata contributes to the creation of a more digital and sustainable Italy.

The company's strong commitment was recognised at national level with the inclusion of Unidata in the **2023 Growth Leaders ranking**, a list produced by the international company Statista, specialising in economic research and statistics, in collaboration with the Sole 24 Ore publishing group.

Unidata was selected as one of the Italian companies that had the most significant and fastest growth in turnover in the three-year period 2018-2021, entering the ranking for the important contribution and support provided to the Italian market.

Its contribution to the country's economy was made possible by its achievements on several levels, including:

- projects to extend its FTTH optical fibre network in the grey areas of Lazio - under an investment agreement with CEBF (Connecting Europe Broadband Fund) - through the newly established company Unifiber;
- admission to the Euronext Growth Milan market (formerly AIM) of the Italian Stock Exchange;
- the design of a new Data Centre and the IoT solutions implemented in Smart Water Metering with the LoRaWAN® network.

### Services provided by Unidata

The services offered by Unidata played a fundamental role in coping with the Covid-19 emergency, and still today represent an essential support tool for smart-working, online education in both public and private education. Unidata has guaranteed, and still guarantees today, Internet access services

for the organisation of online events and the generalised use of digital services and contents, affirming itself for its Cloud functionality for data storage, processing, and transmission.

Unidata operates in the telecommunications sector as an Internet Service Provider, dividing its activity into: **Fibre & Networking, Cloud & Data Centre to which the IoT and Smart Solutions** business is added.

The company has a fibre-optic network of its own construction and ownership, as well as the Data Centre needed in the provision of Hosting and Cloud Computing services, strategically linked to the provision of access and fibre-optic network services.

Unidata is an authorised operator of:

- public network services;
- public voice telephony services throughout the country;
- public Wireless Wi-Fi and licensed band (26 GHz) services over the entire Lazio region.

The specialised services offered by Unidata are divided into:

- fibre optics and connectivity;
- cloud and data centres;
- fixed telephony;
- Internet of Things (IoT);
- ancillary services and products

Unidata's collaboration with Enel X and ZTE, which began in May 2021, has resulted in the new 'Gigafiber Smart Home' offer, the first integrated connectivity solution for increasingly advanced home automation management. The device integrates Unidata's superfast connection with all the functionalities of Enel X's Homix smart home, offering customers an increasingly evolved and integrated service.

In 2022, technological innovations have made it possible to guarantee surfing speeds of up to 2.5 Gbps to carry out all domestic and work activities with complete autonomy. This is a service with a very high level of performance, both in terms of connection speed and the transmission of information.

Continuing this trend, Unidata has set as its 2023 target the launch of an ultra-broadband fibre-optic access service on the XGS-PON network, with a speed of up to 10 Gbps, which will quadruple the connection speed of the current 2.5Gbps peak service.

With the launch of 10 Giga, the company will offer its customers an even more powerful and stable connection with less latency. Unidata will be among the first companies to launch the 10 Gbps service, as it was for the 1 Giga service, confirming its position as a leader in innovation.

With this investment, the company aims to ensure the best available technology.

GRI 102-05 102-07 102-18 102-20 102-23 405-01

## 2.3 Corporate Governance

Corporate governance can be defined as the set of subjects, rules, laws, and procedures that determine and control corporate management and encompasses stakeholder relations and the strategic purposes for which a company is administered.

Unidata has equipped itself with a corporate governance structure designed to make the set of rules and decision-making processes extremely efficient, as well as the tools used to achieve, and measure results effectively.

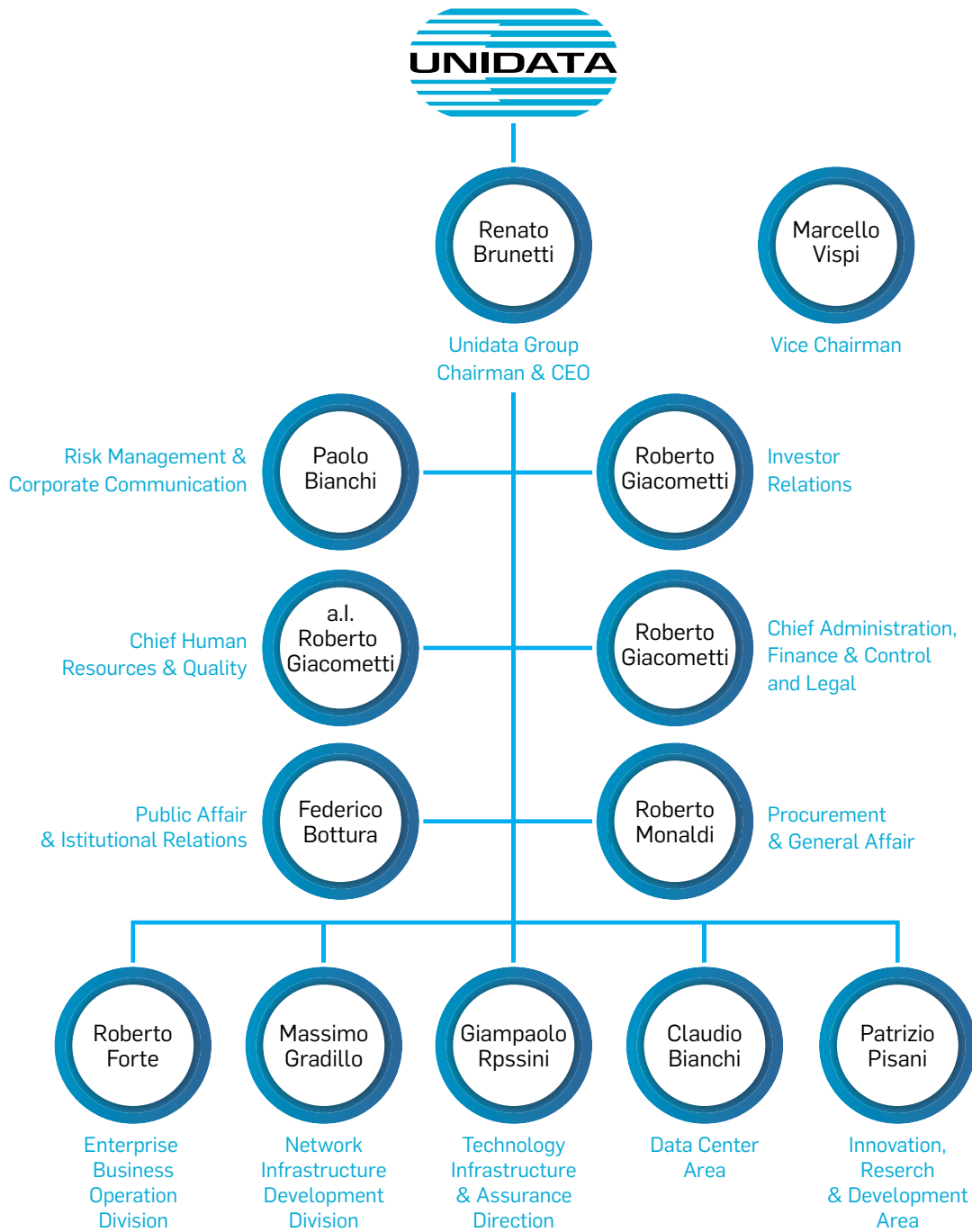

Figure 4 - Graphic representation of the corporate organisational structure

Unidata sees corporate governance as a key element in consolidating trust in the market: it pursues the principles and practices of good corporate governance to strengthen the relationship with its investors. The system adopted by the company is oriented towards

guaranteeing transparent and responsible management of its activities towards third parties, employees, collaborators, shareholders, and the market in general, with a view to the pursuit of social goals.

### 2.3.1 The Shareholders' Meeting

On 16 March 2020, Unidata was officially admitted to listed trading on the Italian stock exchange.

Originally, 439,100 shares were subscribed to, but following the exercise of the Warrants during 2020, 2021 and 2022, the development of which will be detailed in section "2.5 Economic performance and distribution of value", the shares were distributed as follows at the end of the 2022 financial year:

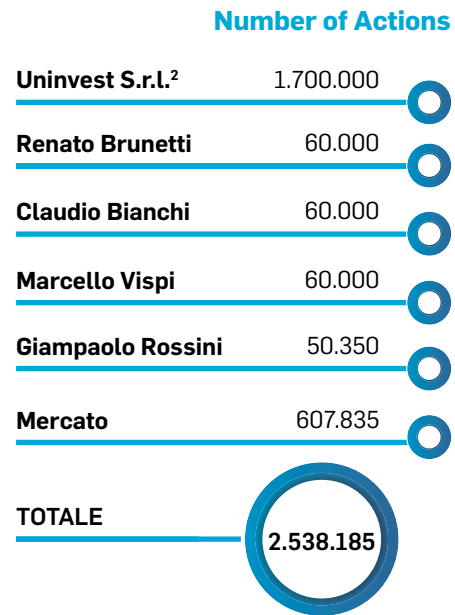

Table 4 - Breakdown of actions

The company structure is therefore as follows:

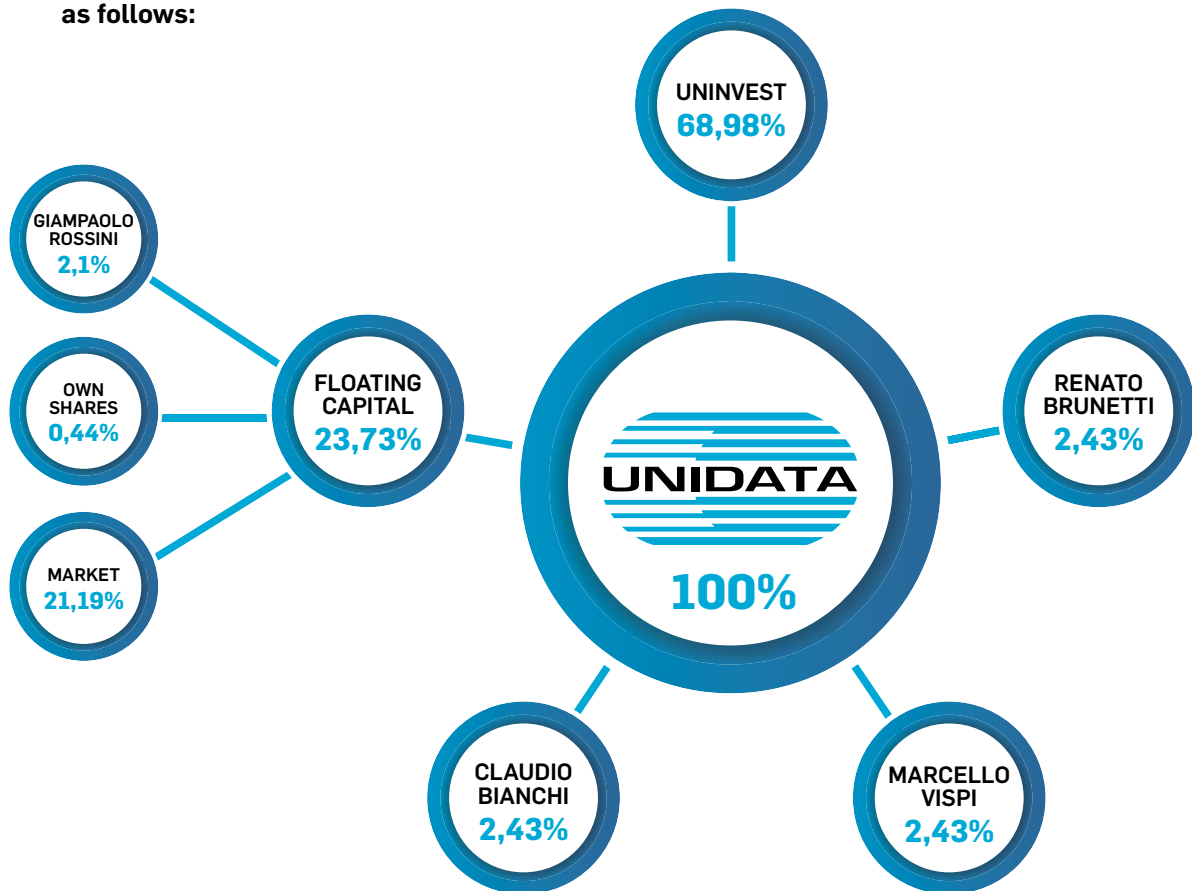

Table 5 - Unidata shareholders

2 - Uninvest S.r.l. is equally owned by shareholders Renato Brunetti, Marcello Vispi and Claudio Bianchi.



### 2.3.2 The Board of Directors

The Board of Directors (BoD) is vested with the powers for the ordinary and extraordinary administration of Unidata, with the authority to perform all appropriate acts for the achievement

of the corporate purposes, with the exclusion of acts reserved - by law or by the Articles of Association - to the Shareholders' Meeting.

**Unidata's Board of Directors is composed as follow:**

#### **RENATO BRUNETTI** President

Since 1970 in the ICT sector, he began his career as an expert in computer systems and software projects and was involved in research and development and marketing in companies in the IT sector. In 1985, together with two partners, he founded Unidata, which is still in business and is dedicated to microinformatics, networks and system integration. He is among the forerunners in Italy in dealing with the Internet as early as 1994, becoming one of the first consultants in the ISP sector. He is President of the **NaMeX** Consortium and Vice President of AIIP, the Italian Internet Provider Association. He has been Chairman of the Board of Directors since December 2002.

#### **MARCELLO VISPI** Councillor

Since 1970 in the ICT sector as an expert in information systems and software projects, he has been involved in the development of PC operating systems, implementation of software applications and R&D for companies in the IT sector. He is one of the founding partners of Unidata.

#### **GIAMPAOLO ROSSINI** Councillor

In the company since 1997, he has been a partner in Unidata since the beginning of 2000 and has been a member of the Board of Directors since March 2006.

#### **PAOLO BIANCHI** Councillor

In 2013, he joined Unidata as Administrative Secretary at the Italian Internet Provider Association (AIIP), under the chairmanship of Renato Brunetti. Since 2015 he has been at Unidata as Assistant to the President, Coordinator of Communication Activities and, more recently, as Investor Relations Assistant. He holds an executive master's degree from LUISS Business School in Project Management and an executive master's degree in Content Marketing organised by Ninja Academy together with the Salesian University of Venice (IUSVE).

#### **STEFANO CIURLI** Councillor

An expert in telecommunications thanks to the important roles he has held in Telecom Italia for over 30 years. Most recently, between November 2015 and March 2018, he was Vice President of Telecom Italia's Wholesale division, reporting directly to the CEO. During this period, he was responsible for the development of Fibre Optic cabling in the national territory, managing more than Euro 1.5 billion of investments per year and cabling more than 18 mln Real Estate Units. He is currently CEO of PTS Group (holding company) and PTSCLAS Consultancy, two strategic consultancy companies.

#### **ALESSANDRA BUCCI** Independent director

Marketing and Sales Director with over 25 years of experience in Fast Moving Consumer Goods (Unilever), Pharmaceuticals (Bristol Myers Squibb) Telco (TIM) and Rail (Trenitalia).

#### **BARBARA RICCIARDI** Independent director

He performs his professional activity in his own right assisting clients in corporate and tax matters, he is Standing and Substitute Auditor at national companies and Legal Auditor of the Order of Architects of Rome. She has been a member of the Assembly of Delegates of the Cassa di Previdenza ed Assistenza dei Dottori Commercialisti since 2016 and until 2024. She is a member of Nedcommunity-Associazione italiana amministratori non esecutivi e indipendenti (Italian Association of Non-Executive and Independent Directors) and participated in the third refresher course The Effective Board (TEB) organised by AIDC Sezione Milano and Nedcommunity.

Table 6 - Composition of Unidata's Board of Directors

### 2.3.3 The Board of Auditors

The Board of Statutory Auditors is vested with the powers prescribed by law and the Articles of Association. As the Audit Committee, it supervises the financial reporting process, the effectiveness of the Internal Control and Risk Management System, the statutory audit of the annual and consolidated accounts and the independence of the statutory auditor.

The Board also monitors compliance with the provisions of Legislative Decree 254/2016 on non-financial reporting, reporting in its annual report to the Shareholders' Meeting.

**The Board of Statutory Auditors is composed as follows:**

Table 7  
Composition of Unidata's  
Board of Statutory Auditors

Pierluigi  
Scibetta

Chairman of the Board  
of Statutory Auditors  
since October 2007

Stefano  
Grossi

Full Auditor  
since January 2003

Antonia  
Coppola

Standing Auditor  
since May 2017

Antonella  
Cipriano

Alternate Auditor

Luigi  
Rizzi

Alternate Auditor

### 2.3.4 The Management

Unidata's management encompasses all administrative, managerial and management functions necessary for the development of the most efficient strategies. The administrative body is in charge of planning commercial, operational and financial decisions, coordinating the organisation in all its areas, in order to achieve common objectives for the benefit of the entire business.

The task of the top managers is therefore to manage the activities effectively, to ensure that the company achieves its objectives in line with the Mission.

**Management is currently structured as follows:**

Table 8  
Management Composition  
of Unidata

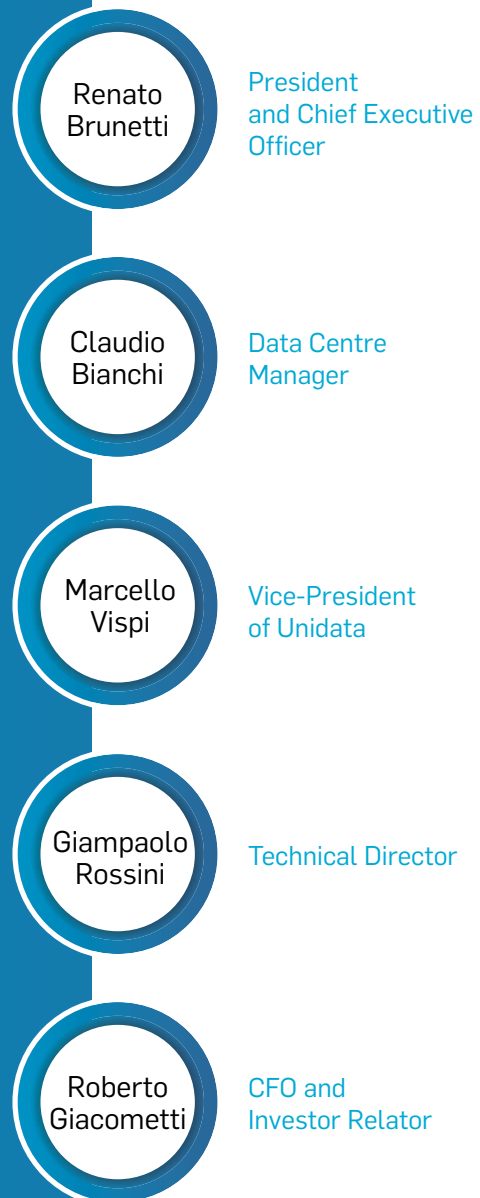

## 2.4 Internal Control and Risk Management System

The Internal Control and Risk Management System is the set of tools, organisational structures, standards, and corporate rules aimed at conducting the business in line with the corporate objectives defined by the Board of Directors.

Control takes place through an appropriate process of identification, measurement, management and monitoring of the main risks, as well as through the structuring of adequate information flows to ensure the circulation of information.

One of the tools used to prevent corporate risks is the adoption of the Organisation, Management and Control Model pursuant to Legislative Decree 231/01, which aims to prevent the administrative liability of companies for certain offences committed materially by directors, representatives, or employees in the interest and to the advantage of the company itself.

Unidata has its own Organisational, Management and Control Model, a Code of Ethics - as a charter of ethical and social values for all those involved in the company - and has entrusted a Supervisory Board, endowed with autonomous powers of initiative and control, with the task of supervising the operation of and compliance with the Model and ensuring that it is updated.

The Model adopted by Unidata is consistent in its contents with the provisions of the Decree and is part of the Company's broader policy aimed at raising the awareness of both internal staff and external collaborators and business partners to transparent management that complies with the regulations in force and the

fundamental principles of ethics in the pursuit of the corporate purpose.

The organisational model 231/01 will be updated at the beginning of the financial year 2023.

Unidata has also adopted the EQS Integrity Line software to minimise whistleblowing. The EQS Integrity Line is a secure, anonymous whistleblowing hotline that allows employees to report wrongdoings such as corruption, abuse of authority, discrimination, and harassment internally before contacting the authorities or the media. The encrypted channel guarantees the highest possible protection for whistleblowers.

### 2.4.1 The Supervisory Board

The Control and Supervisory Board was renewed by the Board of Directors at its meeting of 30 April 2021, after having ascertained the requisites of honourableness, professionalism appropriate to the role to be covered and the absence of causes of incompatibility and conflict of interest with other functions and/or corporate positions that could undermine its independence and freedom of action and judgement.

It consists of:



Maria  
Teresa  
Colacino

President

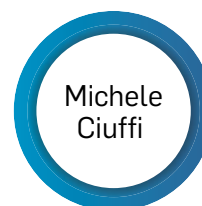

Michele  
Ciuffi

Assistant Member

In the course of 2022, the Supervisory Board ensured that:

- monitor the effectiveness of the model, i.e., the consistency between the concrete conduct and the established model;
- examine the adequacy of the model, i.e., its actual capacity to prevent the prohibited conduct;
- verify that the model's robustness and functionality requirements are maintained over time.

Lastly, it should be noted that during the year 2022, the Supervisory Board did not receive any reports of the commission or attempted commission of any of the offences covered by Legislative Decree no. 231 of 8 June 2001. As a matter of fact, neither fraudulent violations or circumventions of Unidata's Organisational Model nor circumstantiated reports of unlawful conduct that did not comply with the provisions of the Code of Ethics emerged.

#### 2.4.2 The Code of Ethics

Unidata has demonstrated, as in the previous year, that it is sensitive to the principles of corporate social responsibility and is committed to ensuring conditions of fairness and transparency in the conduct of business activities, to protect its position, its image, the expectations of its shareholders and the work of its employees.

The importance of developing a business characterised by strong ethical values, justice and respect for human rights is confirmed by the constant updating of its Code of Ethics, which is a fundamental component of the company's Internal Control System and corporate culture tool.

The Code of Ethics formalises the set of core values, reference standards and rules

of conduct of the company. It establishes binding principles - without exception - for all company representatives, employees and any other person acting, directly or indirectly, in the name and on behalf of the Company. In a constantly evolving context where attention to ethics represents a fundamental value, the implementation of the Code of Ethics assumes strategic importance.

Unidata prescribes, for all those who collaborate with it, observance and maximum dissemination of the code and undertakes, as demonstrated so far, to continuously monitor its compatibility with the evolution of the reference regulatory framework. The usability of the document by users is ensured by its publication on the company's institutional site, at [www.unidata.it](http://www.unidata.it), in the area dedicated to 'corporate ethics'.

For Unidata, it is essential that effective and efficient management is accompanied by appropriate social involvement and respect for the environment, as evidenced by the start of the procedure to become a Benefit Corporation, which is set to be completed in 2022.

The pursuit of common benefit, proper to the Benefit Corporation, is reflected in the ability to combine and integrate different objectives in the realisation of the corporate mission such as:

- attention to the needs of the community and the protection of the environment;
- the promotion of a working environment inspired by respect, fairness, cooperation, and the enhancement of professional skills.

The commitment that Unidata associates with this transformation is in the continuous and lasting improvement of processes, skills and performance while respecting

the environment and communities for a development with a positive impact on Profits, Planet and People.

### 2.4.3 The Enterprise Risk Management

In 2021, Unidata developed its Enterprise Risk Management (ERM) project aimed at the comprehensive and integrated management of risks, through systematic activities such as risk identification, measurement, evaluation and treatment.

To meet the growing need for structuring the company organisation, Unidata therefore decided to undertake a risk assessment with the aim of increasing the company's value for the benefit of its stakeholders by supporting its objectives, through:

- the provision of a methodological framework that allows for a coherent and controlled development of all future activities;
- the improvement of the decision-making process;
- planning and prioritisation through a comprehensive and structured understanding of the activity itself.

The reference standards for the development of the ERM model valid for Unidata are:

1. the *ISO 31000 standard Risk management - Principles and guidelines*. According to these guidelines, risk management is described as a process whose objective is to provide reasonable certainty that the objectives defined in the planning phase will be achieved, guaranteeing a residual risk below an acceptable threshold.
2. The *Committee of Sponsoring Organisation (CoSO) ERM framework*. It is a model of international standing that aims to determine the "quantum" of Risk that a

company/entity is willing to accept to create value for its stakeholders and provide a single reference for managing the various types of uncertain events effectively, in relation to the pre-established objectives

The assessment was carried out according to the following sub-phases, carried out in cooperation and with the information support of Unidata's top management:

1. the identification of significant risks to which the company is exposed;
2. the identification of the Threats underlying the identified Risks;
3. the assignment of a frequency value for each identified Threat (M);
4. the identification of the Vulnerabilities underlying the identified Risks;
5. the assignment of a Vulnerability value (V) for each Vulnerability identified;
6. the identification of Impact categories;
7. the assignment of an Impact value (I) of each identified Threat (M);
8. the calculation of the probability of occurrence (P) of a certain Threat (M) with respect to Vulnerabilities (V), obtained as the product of the probability of occurrence of a Threat by the resulting Vulnerability levels:  $P = M \times V$ ;
9. the calculation of the Risk level (R) associated with each Threat or Impact, calculated by multiplying the probability level of each Threat (P) by the Impact value (I) associated with it with respect to the Impact categories:  $R = P \times I$ ;
10. the calculation of the Risk level for each business area.

The Threat represents a potential event that can materialise into a Risk for Unidata.

From the information collection carried out, the following categories of **Threats** were



identified as potential events that could materialise into Risks for Unidata:

- **Environmental/Geopolitical:** Threats related to environmental and geopolitical events that may have an impact on Unidata.
- **Market:** Threats related to market aspects that may have an impact on Unidata.
- **Suppliers:** Threats related to events causing impacts on suppliers or relations with suppliers that may have an impact on Unidata.
- **IT/Cyber:** Threats related to malicious or accidental events that involve the IT network and may have an impact on Unidata.
- **Legal/Compliance:** Threats related to legal and compliance aspects that may have an impact on Unidata.
- **Reputational:** Threats related to reputational aspects that may have an impact on Unidata.
- **Contractual Requirements:** Threats related to aspects of contractual requirements that may have an impact for Unidata.

- **Human:** Threats related to human aspects that may have an impact on Unidata.

The overall average Threat Occurrence Frequency Index for Unidata presents a general picture of a 'Low' incidence of the events analysed.



Figure 5 - Average threat frequency index for Unidata

The Threats with a higher frequency of occurrence belong to the IT/Cyber, Legal/Compliance, Suppliers and Reputational categories. In particular, they concern:

- *Malware infections*

- *Phishing*
- *Personal and confidential data breach*
- *Hostile media activities*
- *Increased cost of supply of energy sources and/or other essential supplies*

Vulnerabilities represent a condition of weakness that may allow a Threat to have an Impact on Unidata's assets.

From the study carried out, the following **Vulnerability** categories emerged for Unidata:

- **Compliance:** Vulnerabilities related to compliance and regulatory compliance aspects.
- **Communication:** Vulnerabilities related to communication aspects both in relation to the company (internal and external communication) and to areas of the company (horizontal and vertical communication).
- **HR:** Vulnerabilities related to human resources management aspects.
- **IT:** Vulnerabilities related to technology and cybersecurity aspects.
- **Management:** Vulnerabilities related to corporate management.

The overall average Vulnerability Index for Unidata presents a general picture that reveals a **'High'** level of exposure of the organisation to the Threats considered.



Figure 6 - Average vulnerability index for Unidata

Unidata's security level is considered from the assessment of the implementation of measures to deal with each Vulnerability, associating with each Vulnerability one or more Checks whose completion determines the level of implementation.

The most significant Vulnerabilities are those belonging to the Compliance, Communication, HR, and Management macro-areas. Specifically, the most significant vulnerabilities concern:

- *Management and Dimensioning of the Legal Area*
- *Duty of Disclosure and Transparency of Communications*
- *Procedures and Processes for Internal Cooperation and Communication*
- *Management and growth of staff soft skills*
- *Tools for monitoring soft skills and productivity KPIs*
- *Supply chain continuity and supply chain security policies.*

Impacts represent an estimate of the consequences that Threat events may have on Unidata, regardless of the Probability of occurrence.

The following **impact** categories were identified for Unidata:

- **Reputational:** Impact on stakeholders' judgement and trust on the reputation of the brand, the product or the company as a whole (e.g., reduced level of customer retention and satisfaction, reduced trust from investors and lenders, manifestation of negative judgement in the media, etc.).
- **Financial:** Impact on loss of earnings and consequential damage.
- **Operational:** Impact on typical business activities, the level of effectiveness and efficiency of primary and support processes.
- **Strategic:** Impact that determines the



non-achievement of the business plan's corporate objectives and leads to a deviation from the industrial strategy set out in the business plan.

- **Market Coverage:** Impact leading to a reduction in the percentage of the market covered.
- **Competitive advantage:** Impact involving the loss of elements of a service or product's competitive advantage.

The overall Medium Impact Index for Unidata presents an overall picture that shows a 'Medium' level of impact for the organisation.



Figure 7 - Average impact index for Unidata

Threats that were found to have a significant level of Impact belong to the Threat categories:

- **IT/Cyber:** the most relevant threat concerns possible breaches of data subject to retention for judicial purposes (data breach) since, although no incidents are recorded in the company's history, the consequences from a legal and reputational point of view would be onerous.
- **Legal/Compliance:** the two Threats that were assessed with a relevant level of Impact are respectively: the detection of corporate non-compliance with GDPR and AGCOM regulations.
- **Market:** the threats to the company relate to a reduction in the number of business/

PA customers, a reduction in installation activity due to saturation of network infrastructure, and the unavailability of close substitutes about purchasing and supplies/unique suppliers around installation of supplies. Regarding business/PA customers, the assessment was made considering that Unidata has a percentage of business/PA customers equal to about 85% of the total, and a reduction of the same would result in very high costs both financially and in terms of internal personnel management, since Unidata's employees are mainly qualified to manage the business sector rather than the residential sector. About the reduction of the network infrastructure installation business, it has been assessed how Unidata's business is mainly focused on the realisation of these infrastructures and how the saturation level of these infrastructures at national level is now an established fact. This, in the long term, will entail costs both financially and operationally because technical personnel specialised in such activities would not be easily retrained for the other services offered by Unidata

- **Suppliers and Contractual Requirements:** The Threat regarding the unavailability of close substitutes regarding procurement and supplies/unique suppliers in the area of supply installation, as such suppliers, especially in the wake of the NRP, may be increasingly difficult to find. This could easily lead to increased costs due to increased demand. The problems identified, therefore, concern the retention of current partners and the recruitment of new suppliers to cope with Unidata's current projects.
- **Reputational:** only one Threat related to scandals concerning management or brand testimonials is reported. This asses-

sment was estimated considering Unidata's stock market listing and the relevant regulatory obligations, including internal regulations, which increase the potential Impact of this Threat, especially on the Compliance and Reputational categories, should a leading element of the company be involved in a scandal.

- **Human Capital:** The Threat could be revealed in the absence for health reasons of a significant percentage of human resources. This assessment was estimated considering how this Threat would have a potentially critical Impact for all categories of Impacts considered. However, it should be noted that Unidata, during the recent pandemic crisis, did not encounter any Penalising Impacts in this respect from a business continuity perspective.

The outcome of the Risk Assessment relative to Unidata's context of reference reveals

an overall level of **"Medium-High"** Risk. This result implies the need to prepare a plan for the identification and application of specific remediation measures, in order to address the identified Vulnerabilities.

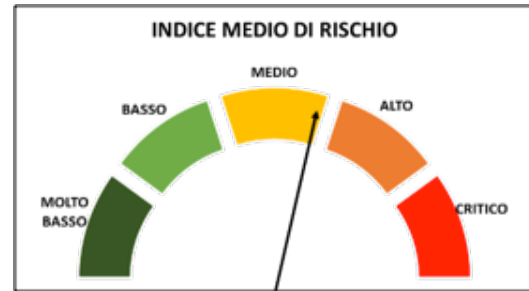

Figure 8 - Average risk index for Unidata

The Risk level represents a measure of how likely it is that a Threat will generate a certain Impact on Unidata and is calculated as the product of the Maximum Likelihood of each Threat (P) by the Maximum Impact level (I) associated with the chosen categories:  $R = P \times I$ .

### Risk Level by Business Area

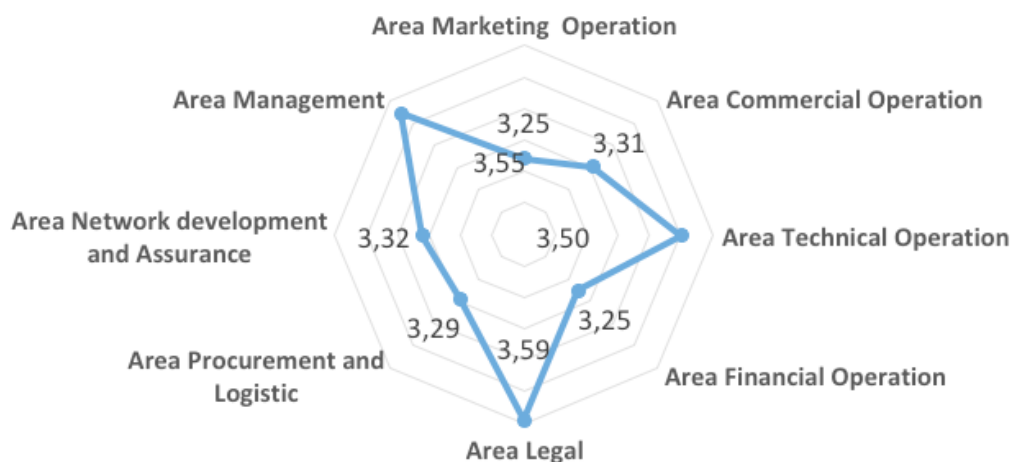

Figure 9 - Risk level by business area at Unidata

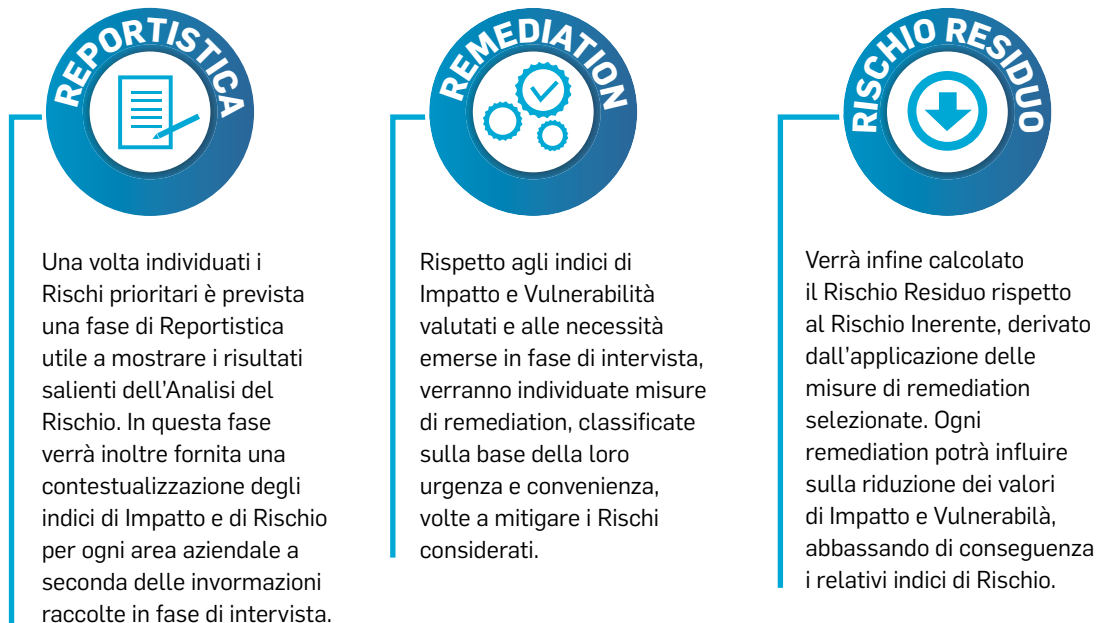

Figure 10 - Risk Management Information Flow

Threats characterised by a significant level of Risk for Unidata belong to the categories:

- **IT/Cyber**, where the most relevant Threats concern possible breaches of personal and confidential data and data subject to retention for judicial purposes (data breach);
- **Legal/Compliance**, regarding Threats of Detection of Corporate Non-Compliance with AGCOM and GDPR.

In light of the findings of the Risk Assessment, remediation measures were identified in 2022 to mitigate the Medium Risk level for the organisation by acting on the individual Vulnerabilities detected and

mitigating the potential Impacts derived from the High Risk Threats<sup>3</sup>.

The first remedial action was the appointment of a Risk Manager within Unidata: Paolo Bianchi will oversee disseminating of the risk culture in the company and will play the role of facilitator for the treatment of risks in collaboration with the various risk owners. The support of this specialist figure is indispensable within particularly complex structures such as that of Unidata.

The table below summarises the results of the 2022 assessment with the relevant remediations and a classification in terms of probability of occurrence and potential impact.

3 - The formula for calculating the individual risks used in the methodology is as follows:  $R=P \times I=M \times V \times I$

AREA	REMEDIATION	PRIORITIES
<b>COMMUNICATION</b>	Programming exercises for staff at all levels aimed at validating and testing existing communication procedures	MEDIUM
	Drafting procedures and processes for Communication, Sharing and Collaboration	MEDIUM
<b>TRANSVERSAL ROLES</b>	Formalisation of cross-area coordination roles	HIGH
<b>LEGALE</b>	Inclusion of additional resources in the legal area	HIGH
<b>SUPPLIERS/ PROCUREMENT</b>	Introduction of a methodology for the classification and monitoring of critical suppliers	LOW
	Introduction of Processes and Procedures for Supply Chain Continuity & Security Management	MEDIUM
	Review and extension of procurement plans based on collected KPIs	LOW
	Inserting or updating tools to monitor productivity, expenditure and purchasing needs of corporate areas	LOW
<b>HR WORK - RELATED STRESS</b>	Inclusion of questionnaires for work-related stress measurement and KPI monitoring	LOW
	Inclusion of psychologist assessment for work-related stress and KPI monitoring	LOW
	Inclusion of psychologist assistance for work-related stress	LOW
<b>HR-TIME CONSUMING</b>	Inclusion of methods and tools for time consuming and KPI monitoring	LOW
	Inclusion of team building activities	LOW
	Inclusion of time management courses	LOW
<b>MANAGEMENT</b>	Inclusion of additional resources in the management area or training of staff aimed at decentralisation of responsibilities and redundancy of management figures	HIGH
<b>TRANSPARENCY</b>	Inclusion of GDPR privacy regulations documentation on the site	MEDIUM
	Review of mandatory stock exchange communications and publications	MEDIUM
<b>CHANGE MANAGEMENT</b>	Incorporation of business processes for change management	HIGH

AREA	REMEDIATION	PRIORITIES
<b>AWARENESS &amp; TRAINING</b>	Checking compliance preparedness in the execution of daily work through checks, exercises, and review of the company's disciplinary policy	HIGH
<b>IMAGE</b>	Improving the management of social media management aspects by assigning new responsibilities to the social media manager or hiring a social media manager	HIGH
<b>BUNKER</b>	Upgrading of machines and systems used for data retention for judicial purposes	HIGH
<b>CUSTOMER SERVICE</b>	Introduction of instrumentation for monitoring Customer Service KPIs (average response time, number of calls, customer history)	MEDIUM
<b>CYBER SECURITY</b>	Updating organisational and technological measures for cybersecurity management and updating obsolete operating systems and applications	HIGH

Table 9 - Classification of identified remediations

From the analysis of the various types of risks that could hinder the pursuit of the company's strategies, it emerged that the main remediation required was the reorganisation of the HR function, carried out in parallel with a staff assessment process to be followed by planned training and coaching activities.

The identification of risk probabilities also revealed gaps in terms of organisation and internal communication processes within the company:

- Establishment of a Staff Meeting held on

a weekly basis according to a schedule of four types of meetings;

- creation of a corporate intranet to foster internal communication with all stakeholders in the company.

To ensure an effective risk management system to help the company manage and overcome the majority of critical issues, increasing its competitiveness in the market, a review of the *heatmap* for risk treatment and remediation will be periodically submitted to the Management.

## 2.5 Economic performance and value distribution

Unidata generated total revenues of € 51,348,376 and a net profit of € 7,504,220 in the financial year just ended

Below are the key economic figures of Unidata's Ordinary Budget 2022:

	2022	YoY	2021
Total Revenues	51.348.376	<b>28%</b>	37.001.539
Production costs	-31.077.257	<b>37%</b>	-19.538.141
<b>Added Value</b>	<b>20.271.119</b>	<b>14%</b>	<b>17.463.398</b>
Labour costs	-4.031.483	<b>16%</b>	-3.371.257
<b>Gross Operating Margin - Ebitda</b>	<b>16.239.636</b>	<b>13%</b>	<b>14.092.141</b>
Depreciation	-5.517.051	<b>10%</b>	-4.987.626
<b>Operating Income - EBIT</b>	<b>10.722.585</b>	<b>15%</b>	<b>9.104.515</b>
Balance Financial Management	-68.632	<b>-313%</b>	-283.400
<b>Profit before tax</b>	<b>10.653.953</b>	<b>17%</b>	<b>8.821.114</b>
Income Taxes	-3.149.733	<b>69%</b>	-977.427
<b>Net Result</b>	<b>7.504.220</b>	<b>-5%</b>	<b>7.843.688</b>

Table 10 - Unidata's Value Added Income Statement as at 31 December 2021

By distinguishing the company's activities by business lines, it is possible to analyse their significant contribution in each area.

### *Fibra & Networking*

This revenue line includes revenues from Internet access services in fibre optic, XDSL and wireless modes, voice telephony and wholesale services.

Its value in 2022 is € 13,791,496, an increase of 16% over the previous year.

The table below shows the development of the number of customers and the average monthly ARPU value.

The tables show the development of the number of customers and the average monthly ARPU value.

CUSTOMERS	2022	2021	Var. YoY%
Business and P.A.	1.925	1.777	<b>+8%</b>
Microbusiness	372	413	<b>-10%</b>
Consumer	14.890	10.996	<b>+35%</b>
Wholesale	22	13	<b>69%</b>
<b>TOTAL</b>	<b>17.209</b>	<b>13.199</b>	<b>+30%</b>

Table 11 - 2022/2021 comparison of the number of customers

CUSTOMERS	2022	2021	Var. YoY %
Business and P.A.	504,74	503,63	+0%
Micro business	74,79	71,96	+4%
Consumer	22,81	23,97	-5%
Wholesale	2.892,90	2.815,70	-3%

Table 12 - 2022/2021 comparison of monthly ARPU<sup>4</sup>

The Average Revenue Per User (ARPU) is an indicator of the profitability of a product based on the amount of money generated by each of its users. It is a particularly useful measure for companies in the telecommunications and media sectors and is often used by analysts and investors to compare the performance of companies in the same sector.

#### Infrastructure

Revenues related to the infrastructure area recorded a significant increase over the previous year, attributable to the increase in volumes related to the granting of I.R.U. (Indefeasible Right of Use) concession rights to other operators on the fibre-optic network infrastructure constructed by Unidata.

Revenues for the construction of telecommunication infrastructures show an increase of 91% and amount to € 33,431,085 in 2022. This exponential growth is attributable to the increase in works related to the RM Fiber project, which envisages the infrastructure of the metropolitan city of Rome and a large part of the province.

#### Cloud & Datacenter

Revenues for this business area amounted to € 1,485,811, an increase of 38% compared to last year. Unidata's strategic focus is on Cloud and Datacenter services, which are extremely important to complete the offering for business customers and host additional services for residential customers.

#### Revenues IoT & Smart Solutions

In the financial year 2022, the revenue line under consideration amounted to € 117,186. It should be noted that the Company has made significant investments in R&D in previous years, the projects of which have essentially come to an end. Nevertheless, as envisaged in the 2023-2025 Business Plan, the Company also expects substantial growth in the IoT area through new product lines, such as Smart Water Metering, for which the Company will participate in tenders of significant size.

The company is also involved in the development of LPWAN (Lower Power Wide Area Network) technology in this area, adopting the very promising and high-performance LoRa™ technology. The company has also used research projects financed with national and EU funds to develop this technology.

#### Future Forecasts

The company's forecasts for the financial year just ended fully met expectations of growth and improvement.

On 25 November 2022, the company's Board of Directors approved the update of the Business Plan for the three-years 2023-2025. To give greater prominence to the different areas into which the company's business is divided, the Industrial Plan envisages the subdivision of the business into two **Business Units** - called **Retail and Infrastructure** - which in turn are divided into specific subcategories called **Business Lines**.

4 - The annual average monthly ARPU was calculated as the average of the ARPUs of the four quarters 2022.

Below are some of the company's objectives for the year 2025:

1. Total **revenues** of between EUR 72 and 75 million. 72 e 75 milioni di euro.
  - Revenues for the **Retail Business Unit** (customers for TLC & ICT services) are estimated at between EUR 38.9 and 40.8 million. The macro-area of reference includes the following business lines:
    - a) *connectivity and consumer services*
    - b) *connectivity and business services*
    - c) *connectivity and Wholesale services*
    - d) *connectivity and P.A. services*
  - Revenues for the **Infrastructure Business Unit** are estimated at between EUR 33.1 million and EUR 34.7 million. They refer to the new method of ac-

counting for the purchase and resale of materials to systems and orders for the construction of the fibre network, including:

- a) *Openfiber*
- b) *Unifiber*
- c) *other operators*
- d) *beyond the new method of accounting for the purchase and resale of materials to systems*

2. **Ebitda** between EUR 23 and 25 million
3. Cumulative **investments** for the three-year period 2023-2025 amount to approximately EUR 46 million

A graphic representation of the composition of the turnover forecast in Unidata's Business Plan for the three-year period 2023-2025 is provided:

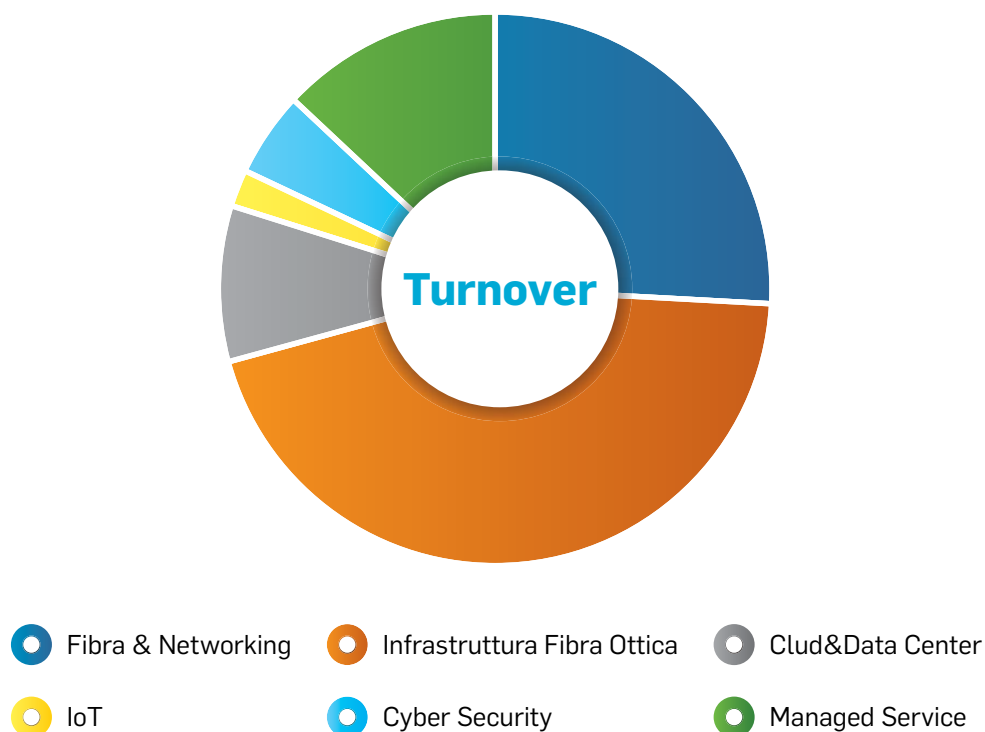

Figure 11 - Turnover composition chart Business Plan





Figure 12 - Unidata share performance 16 March 2020 (IPO) - 31 December 2022

The three-year strategic plan builds on the excellent results achieved in terms of turnover, profitability and number of customers, and is set against a backdrop of strong growth in the domestic market, boosted in part by the availability of the PNRR.

#### Company listing on the EGM

In the three years since 16 March 2020 (the date of the company's IPO), the value of individual shares has increased by around 260% from the initial EUR 13 to EUR 46.6 at the end of December 2022, giving the company a capitalisation of around EUR 118 million. Unidata's admission to listing followed the subscription of 439,100 newly issued shares and 439,100 'Unidata Warrants 2020-2022', through an institutional and retail placement and an offer reserved for employees.

The **first** exercise **period** of the Unidata 2020-2022 warrants had closed on 17 November 2020; 41,000 warrants had been exercised with the subscription of 10,250 new ordinary

shares (at a ratio of one ordinary share for every four warrants held) at a price of EUR 16.90 per share, for a total value of EUR 173,225.

Instead, during the **second** exercise **period**, 61,168 Warrants were exercised and, as a result, 15,292 newly issued shares were subscribed to, with no indication of par value, for a total value of € 258,435.

During the **third (and last)** exercise **period**, **which** ended on 17 November 2022, 294,172 Warrants were exercised and, consequently, 73,543 newly issued shares were subscribed, at a price of EUR 16.9 per share (at a ratio of 1 Conversion Share for every 4 Warrants held), for a total value of EUR 1,242,876.543 newly issued shares, with no indication of par value, for a total value of € 1,242,876. Following this exercise, the new share capital (fully subscribed and paid up) is made up of 2,538,185 shares with no indication of par value.

## 2.6 Implementation of the Fibre Optic Network

Ultra-wide bandwidth is the new unavoidable frontier of connectivity and Italy is gaining ground in this direction by upgrading its infrastructure: with the new installations, data are carried by bundles of very thin fibreglass and plastic polymer cables and travel faster through light pulses. This is currently the most efficient way to connect to the Internet. Unidata has decided to contribute to this process by implementing a connectivity network that has reached entire city areas, bringing super-fast connection even to areas that were in a **digital divide**, i.e. far from the major connection supplies, poorly served or even excluded from the network.

The issue of the **digital divide** is more heartfelt than ever, the road to the completion of these new infrastructures across the whole territory is still long and Unidata is at the forefront of this process. The infrastructure made available and the latest trends in the field of Internet access services is the NGAN (Next Generation Access Network) also known as Ultra internet, i.e., fibre at its maximum power, the protagonist of the new generation of telecommunications networks.

Unidata's wholly owned fibre-optic network is one of its main strengths, enabling it to guarantee a particularly reliable service; part of the 5,450 km installed until 2022 is also granted to other operators through IRU contracts. The IRU (Indefeasible Right of Use, translation 'irrevocable right of use') is a contractual form that allows the acquisition of the exclusive, unrestricted, and non-revocable use of a part of a telecommunications system, which for contracts concluded by Unidata has a duration of 15 years.

Composed and integrated with different technologies, infrastructure architectures and licences, the network offers state-of-the-art services including:

- ultra-wideband connectivity thanks to 100% fibre optic cables;
- VoIP telephony;
- Dedicated VLANs;
- wireless connections;
- IoT - Internet of Things.

By choosing the ultra-wideband of NGAN networks, the company is able to offer all users reached by its proprietary network the maximum performance provided by the FTTH (Fibre to the Home) architecture, which is also the most durable form of investment.

Over time, Unidata has built and commissioned several Pop (Points of Presence), i.e. sites where its telecommunications equipment is installed. These devices, using GPON (Gigabit-capable Passive Optical Network) technology, can provide FTTH-type services to both the SME and residential markets.

Unidata, which has always made its focus on new technologies its strength, is preparing to face the so-called fourth industrial revolution by focusing on IoT technology.

By Internet of Things (IoT) or Internet of Things, we mean that path in technological development whereby, through the Internet, potentially every object of everyday experience acquires its own identity in the digital world. As mentioned, the IoT is based on the idea of 'smart' objects interconnected with each other to exchange the information they possess, collect and/or process.

The first pillar of Unidata's IoT and smart solutions is called UniWAN and is its LoRaWAN® network. For years, the company has been developing and implementing IoT solutions, presenting itself on the market as one of the first IoT Service Providers and setting itself the goal of making systems that are still too often mistakenly considered complex and expensive simpler and more accessible. It is precisely thanks to UniWAN that Unidata is transforming the IoT into a concrete and constantly expanding reality. More and more objects around us can immediately communicate via the Internet.

All spheres will be revolutionised: from the rural ones, which will be empowered by the new IoT agriculture, to the urban ones, which will be transformed into so-called smart cities. The IoT phenomenon is pervasive, although it naturally moves at a faster speed in the business rather than the consumer sphere. However, it concerns, influences, and will influence any market sphere, without exclusions.

Currently, the coverage of the fibre optic network used by Unidata is as follows:

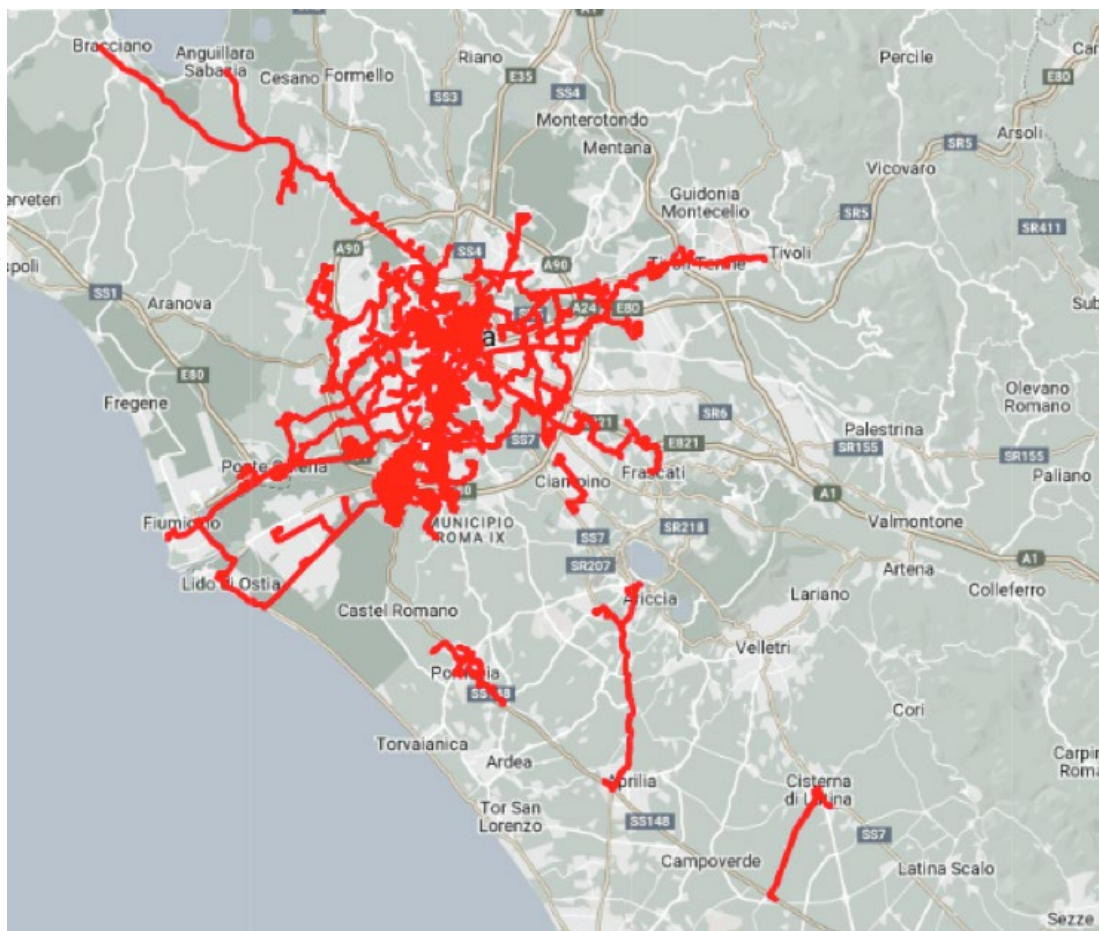

Figure 13 - Fibre optic coverage to 2022

In terms of units reached, Unidata cabled a total of 221,135 IOUs as at 31.12.2022, compared to 149,801 IOUs at the end of the previous year.

The goal for the two-year period 2023-2024 is to expand the existing PoPs (Points of Presence) by cabling an additional 68,300

units to guarantee service coverage to the entire catchment area.

Below are the areas of greatest interest with an indication of the estimated catchment area that is expected to be reached over the two-year period.

POP	Target 2023	Biennium Objective (2023-2024)
Arenula (RM_04)	+6.200	+ 15.000
Castro Pretorio (RM_05)	+21.000	
Malatesta (RM_11)	+21.500	
Garbatella (RM_19)	+800	
Primavalle (RM_28)	+3.000	
Prati (RM_32)	+800	

Table 13- Building Units to be reached in 2023-2024

### 2.6.1 Digitising of grey areas

The telecommunications sector plays a major role within the Italian economic fabric. It not only contributes to employment and national added value, but also enables connections between individuals, the digital economy, and business development: in short, the telecommunications sector is an enabler across all spheres of economic activity.

The lockdown period has made it even more evident that the possibility and ability to use the Internet is crucial today:

- is indispensable for work and professional reasons;
- increases the possibility and speed of access to information while also reducing its cost;
- makes public and private services made available through the network more user-friendly.

Putting as many people as possible in a position to connect effectively and without risk, concretely supporting that part of the population that is currently totally or partially excluded, has now become an absolute priority, not only economically but also socially.

It is, therefore, necessary to accelerate the deployment of ultra-wideband, especially in areas that are not yet served, to allow territories that are today marginalised to become part of a unified national community once again, the digital community.

To digitise Central Italy and overcome the digital divide, Unifiber was established, a company born from the collaboration between Unidata and CEBF.

Unifiber's activities focus on the construction of passive access fibre optic networks of the

FTTH (Fibre To The Home, 100% fibre) type in the 'grey' areas of the Lazio region and the sale of access and use of the networks to other operators.

Once the infrastructure of the network is completed, Unidata will have the right to use it, according to agreements with CEBF, on a pay-per-use basis, allowing it to reach first users who until then did not have access to ultra-fast bandwidth.

On 29 September 2022, Unidata and the Connecting Europe Broadband Fund, or CEBF, signed a supplementary agreement that foresees a doubling of the Real Estate Units will be achieved and a further investment in economic terms by the shareholders.

Unifiber's new investment plan envisages a

total of 193,000 Residential Units and 8,000 Business Units.

In 2022, 71,903 IOUs have already been reached in various municipalities of the Lazio region, corresponding to 571 km of installed fibre. A further 69,000 IOUs are planned to be reached in 2023, for a total of 139,821 cabled units as of 31.12.2023.

The map shows the municipalities that will benefit from the construction of the new network.

It is important to emphasise that, thanks to this project, even citizens and businesses in small municipalities such as Anguillara Sabazia, Bracciano and Palombara Sabina can benefit from innovative services and high-speed FTTH connections up to 1000 Megabits per second.

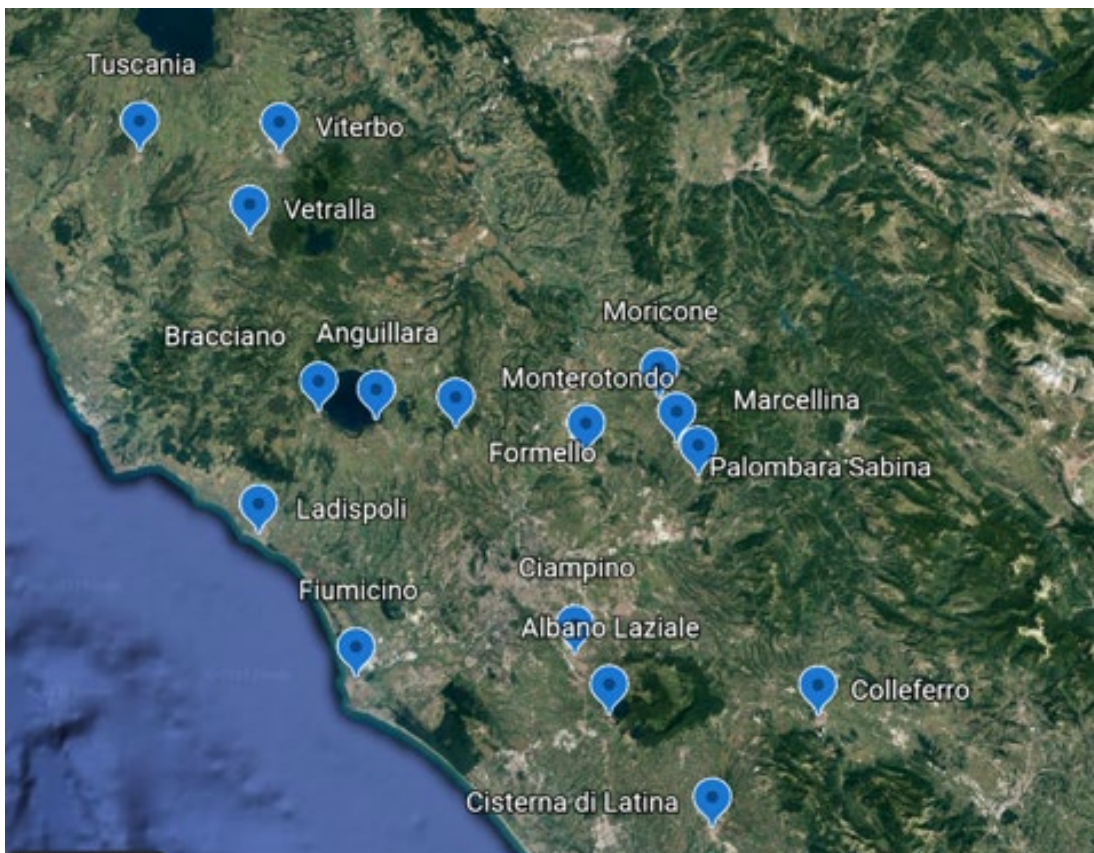

Table 14 - Grey areas to be cabled by the end of 2023

## 2.6.2 Fibre Network Security and Networking

In line with company policy, Unidata's objective is to ensure the integrity, quality and security of the service offered, both for wholesalers and end users. For this reason, the company is committed to preventing possible inefficiencies, as well as controlling the correct functioning of equipment to guarantee high quality standards.

As emerged from the Enterprise Risk Management, the risk of having an inadequate network infrastructure to guarantee service availability levels in terms of reliability was identified and managed with a medium-high level of effectiveness and efficiency. The risk is mitigated thanks to the specific architecture on which the infrastructure is based, the use of high-availability systems and the redundancy of equipment.

The preventive planning activities carried out by the managers follow a well-established process in order to contain possible network malfunctions, and generally, they also include an operational margin to cope with the onset of possible emergencies. Furthermore, preventive maintenance, carried out on various equipment in a satisfactory manner, plays a central role in preventing the risk of service unavailability, precisely because of its precautionary nature.

The monitoring process put in place is structured to prevent critical situations and ensure the proper functioning of the network infrastructure. The signal quality control activities aim to reduce possible signal malfunctions and to allow the timely intervention of the technical teams in the field.

### 2.6.3 The quality of the service

Unidata undertakes to guarantee the quality parameters laid down in the applicable regulations, with reference to the provisions, where applicable, of the resolutions of the Communications Guarantee Authority.

To adequately monitor and manage performance indicators, the company annually updates the quality standards to be pursued

in the provision of its services and communicates them to users.

Unidata publishes half-yearly reports of the monitored technical KPIs and an annual report with the results achieved on its website.

The following quality standards for electronic communication were also identified for 2022.

			2021	2022
<b>Activation Time</b>	First activation orders for a broadband Internet access service to the same operator that provides direct access service for an already active telephone line	Percentage of valid orders completed within the maximum contractual deadline	92,00%	92,85%
		Average calendar days	33,40	29,51
	First activation orders for a broadband Internet access service other than the one providing direct access service for an already active telephone line	Percentage of valid orders completed within the maximum contractual deadline	93,50%	98,29%
		Average calendar days	29,20	26,66
	Change orders from the operator providing the Internet access service for a line where the broadband Internet access service is already active	Percentage of valid orders completed within the maximum contractual deadline	96,60%	78,57% <sup>5</sup>
		Average calendar days	13,80	29,64
	For Wireless Broadband Access Services	Percentage of valid orders completed within the maximum contractual deadline	93,00%	77,78% <sup>6</sup>
		Average calendar days	37,20	28,98
<b>Malfunction rate</b>	a) Service realised with own facilities or Unbundling	Failure rate	1,16%	2,43%
	b) Service realised using wholesale services	Failure rate	2,80%	4,29%
<b>Malfunction repair time</b>	a) Service realised with own facilities or Unbundling	Percentage of malfunction repairs completed within the maximum contractual timeframe	95,30%	95,11%
		Average repair time (including non-working hours)	18,80	25,02
	b) Service realised using wholesale services	Percentage of malfunction repairs completed within the maximum contractual timeframe	64,80%	89,18%
		Average repair time (including non-working hours)	47,60	30,92
<b>Response time to operator customer service calls</b>	Total response time of the human operator	Average response time to incoming calls (seconds)	25,10	25,10
		Percentage of incoming calls where the answer time is less than 20 seconds	88,60%	88,60%
<b>Disputed debts</b>	Percentage of invoices for which the user complained	Ratio of the number of complaints received in the period considered to the number of invoices issued	0,14%	0,15%

Table 15 - Statistics on service quality

5 - Tot ordini anno 2022 n. 15 - campione non significativo

6 - Tot ordini anno 2022 n. 67 - campione non significativo

As part of the general assessment carried out on corporate risks, the need emerged to implement instrumentation for monitoring Customer Service KPIs. This evidence was also given in the assessment on information systems.

In view of the high growth rates in the consumer segment and the related impact on internal Customer Service resources, in 2022 Unidata began the process of outsourcing Customer Service Consumer, which will be completed in early 2023. This process has focused the attention of internal Customer Service resources on requests for assistance from the higher value "Corporate" segment and has delegated the management of 1st level Customer Service calls to CloudCare S.p.A as the company specialising in managing these activities.

In order to ensure proper and more efficient end-to-end customer management, the transfer of the 2nd level Customer Service management (help desk) to Cloud Care S.p.A. was started; this transfer will be completed in early 2023.

Through this breakdown:

- Internal' customer service focused on corporate segment;
- Outsourced' customer service focused on consumer segment;

The company ensured proper management of the increasing scale of operations related to the customer's needs.

GRI 102-29 203-01 103-01 103-02 103-03

## 2.7 Data Centre and Cloud Services development

Data is the most valuable asset for any organisation and equally valuable must be the centre that receives, stores, and processes it to achieve success.

**Unidata's Data Centre has been designed and built to meet the expectations of its users and guarantee the highest quality.**

The definition of a data centre has been the focus of extensive debate and comparison within the international scientific community for years. The organisational unit - consisting of a network, storage space and a computing server - is used to process, organise, protect, and store computer data.

From an infrastructural point of view, the Data Centre is the beating heart of the business because it houses all the equipment that allows processes, communications, and services to be governed in support of any business activity. Owned or outsourced, the CED is the cornerstone of business continuity.

Unidata's Data Centre is located at the head office and is characterised by an architecture that guarantees the constant maintenance of energy and air conditioning to ensure **business continuity** for all customers. Unidata guarantees more than 40 continuous hours of service in the event of a blackout, thanks to the two diesel generators capable of supporting the entire system.



The Data Centre structure is inspired by the n+n redundancy standard (Tier IV compliant): everything is double to guarantee continuity.

The data centre has a Power Usage Effectiveness (PUE)  $\leq 1.2^7$

### Cloud services

When people talk about cloud computing, they mistakenly believe that it is exclusively something ethereal and intangible. Behind every cloud service there is a Data Centre managed by a team of experts, with the aim of offering customers guarantees in terms of data availability, integrity, security, and confidentiality.

The Cloud has taken, and will continue to take, a prominent position in the market due to its ability to enable companies of all sizes to benefit from highly advanced digital services without having to deploy their own servers in-house with state-of-the-art IT infrastructure.

Unidata provides its customers **with housing, hosting, server colocation, backup, disaster recovery, virtual data centres** and the most innovative **cloud storage** services.

Unidata's Cloud Storage allows you to create your own **dedicated Data Centre**, virtual or physical, to renew your customers' IT infrastructure and migrate to the Cloud with ease.

To meet the expectations of the most demanding customers, the company guarantees:

- security, reliability and speed of the infrastructure and the Cloud;
- 99.99% guaranteed SLA level, supported by direct customer service with competent staff on call 7 days a week;
- data security, control of technical premises, through 24-hour surveillance, technological control systems and internal and external video surveillance;
- no greenhouse gas emissions generated.

It is also possible to select the type and sizing of servers to be created, choosing from a range of configured profiles. The Cloud stands as a model for using technologies that can reduce costs and time-to-market, making Information Technology ready to respond to business needs and rapid changes in the external environment.

In 2022, in the current delicate context, the Cloud market, based on energy-intensive infrastructures, is beginning to suffer impacts that will be seen more concretely in 2023. In fact, the situation is one of great uncertainty in the various markets at the Italian and international level: the complex geopolitical situation generated by the events of the Russian-Ukrainian conflict, the ensuing energy crisis and the difficulties that have arisen in countless supply chains, including the worsening of problems in the semiconductor chain, which is fundamental for technological development.

According to the findings of the *2022 Research of the Cloud Transformation Observatory*, the answer to the new complexity lies in the creation of a *Cloud Ecosystem*, characterised by multiple perspectives and players that must work together to make the entire

<sup>7</sup> - Energy efficiency (PUE) is a metric used to determine the energy efficiency of a data centre. It is a parameter used to quantify the electrical power dedicated to powering IT equipment compared to auxiliary services such as air conditioning or UPS losses.

The PUE is determined by dividing the total amount of energy entering a data centre by the energy used to operate the IT equipment inside it.

market sustainable, both economically and environmentally, and resilient to changes in the unstable environment. *Research 2022* itself confirms that, despite the uncertain economic environment, the **Italian Cloud market** is consolidating, with a growth rate of 18% compared to 2021 and a value of **4.56 billion euros**.

To support the Cloud Ecosystem, we remind you that Unidata has signed an investment agreement with the Fondo Infrastrutture per la Crescita-ESG, managed by Azimut Libera Impresa SGR S.p.A., for the construction of a green and neutral data centre.

It will be one of the first green data centres in the country, an ambitious project that renews Unidata's commitment to sustainability, allowing national and international customers who will use it for their cloud and storage needs to minimise their environmental impact.

### 2.7.1 Data Centre Security

Data are to be regarded as a real corporate asset and have therefore also taken on important economic connotations for criminal hackers. It is therefore important to design and manage a data centre according to good business continuity, resilience, and risk management rules in order to protect the customer information it contains.

Security includes best practices and preliminary activities to protect a data centre from threats, attacks, and unauthorised access.

Among others, these two aspects should be given greater consideration:

- physical security, which requires site planning to limit physical break-ins;

- network security, which is implemented by installing firewalls and anti-malware programmes to prevent breaches.

Unidata guarantees adequate security measures to protect its data centres. Efficient protection, in fact, limits the risk that breaches of company or customer data can cause considerable damage both financially and reputational-wise.

As far as virtual security is concerned, Unidata has equipped itself with anti **DoS 'Denial of Service'** services, i.e., systems designed to prevent cyber criminals from deliberately interrupting the company's business continuity. The fraudulent intent is to interrupt, through a targeted action, the connection between any computer (client) and the IT resources, be it the network, a server, an application, or an entire Data Centre. Precisely because Data Centres are connected to external networks via user access portals, virtual protection measures include systems to confirm the identity of authorised users, such as multi-factor authentication, and software to prevent unauthorised users from gaining access, such as firewalls.

Regarding physical security, on the other hand, Unidata has provided different levels of security for its central data centre:

- the first level is characterised by the reliability of the surveillance provided in the Commercium perimeter. The shopping centre is in fact equipped with a 24-hour surveillance and video surveillance service;
- a second level of anti-intrusion security involves a double door to Unidata's premises;
- an additional level of security provided by access controls using task- and intervention-specific ID badges.



The Data Centre area has been strategically arranged so that it does not border on any external walls. The same attentions are also applied to all the external equipment needed to power them; the air-conditioning rooms and generators are in fact protected by steel structures that are only accessible to authorised users. As far as the analysis of sensitive data is concerned, this is only allowed to authorised parties (e.g., the police) following specific requests and, furthermore, the consultation of such data is subject to tracking.

To guarantee the continuity of the services offered, Unidata's Data Centres are structured as follows:

- differentiated access of data transmission cables through a double fibre optic line;
- two different power cabins which are in turn connected to two different power generators. This safety system is activated both in the event of a power failure and in the event of scheduled maintenance to ensure continuity.

To cope with the risk of flooding, Unidata provided:

- the installation of data centres on a floating floor, also known as a floating floor, which involves the interlocking installation of planks, boards or tiles at a certain distance from the surface to be covered. The flooring is usually placed on top of an overhead frame, foam or other subfloor to minimise water accumulation in the event of underground pipework breaking. Ground pumps that are activated in the event of an emergency are also installed;
- state-of-the-art flood sensors;
- cables positioned above the data centres.

To avoid the risk of fire:

- Vezda sensors which are designed to control air smoke;
- inert fire-fighting gas (ARGON 50% AND NITROGEN 50%);
- all equipment is certified;
- automatic unlocking system connected to doors and gates in the event of an emergency.

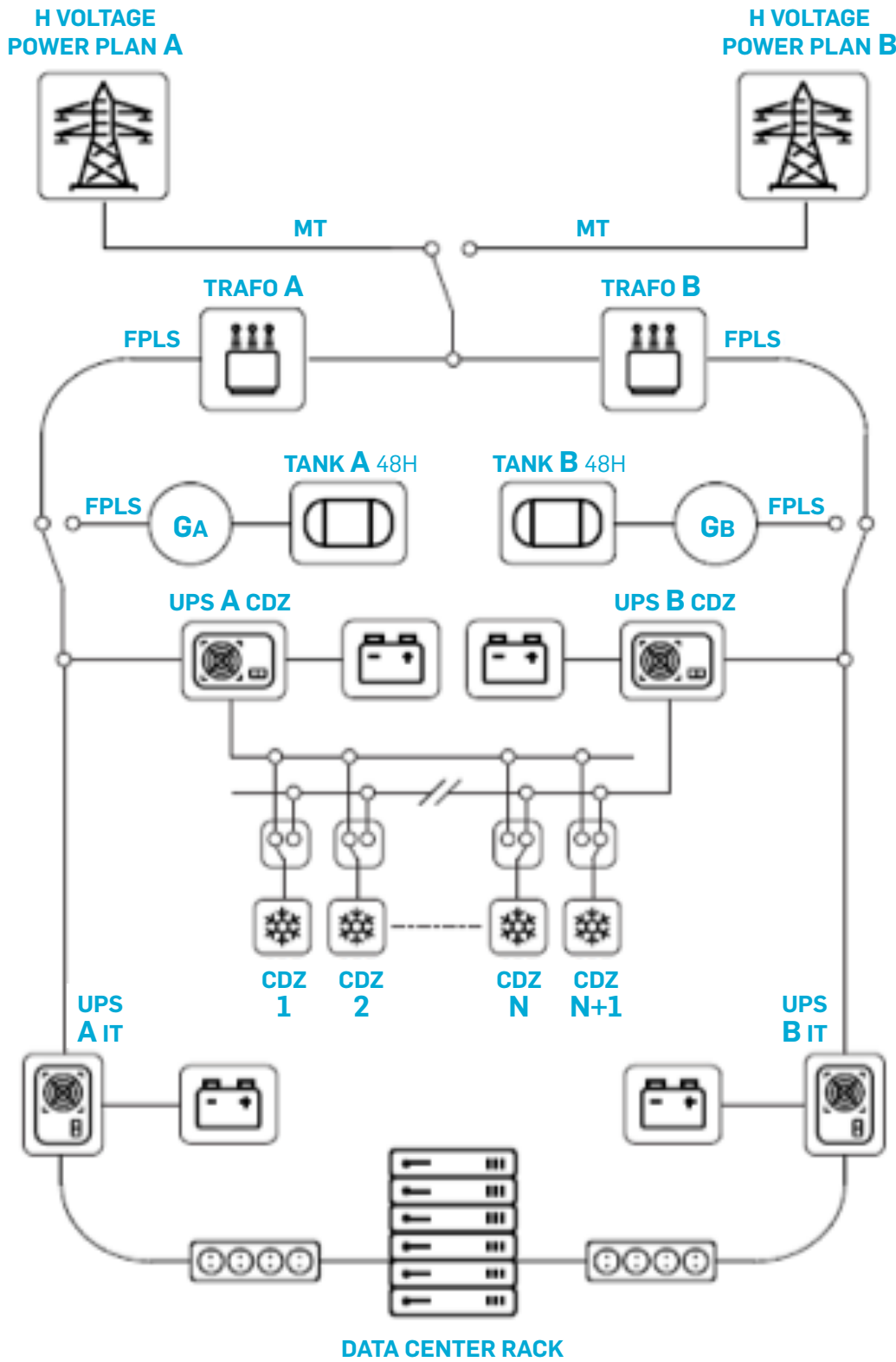

Figure 14 - Unidata Headquarters Data Centre Structure

## 2.8 Cybersecurity

Several recent news episodes have underlined how the topic of cyber security plays an extremely important and topical role. Just think of the conflict between Russia and Ukraine, which has generated an unprecedented cyber war or the frequent attacks on the computer systems of public and private organisations.

In many cases it is not known who he is and why he is doing it. What is clear is that the disaster recovery plan has often not been up to the timeliness that is nowadays expected for strategic services, such as the health and safety of citizens, or those with a high economic impact for companies.

Also considering the huge increase in online cyber fraud - such as phishing (web, mail), vishing (via voice call) and smishing (via sms) - the investments in digital transformation supported by Italy risk being meaningless, if they are not accompanied by tools capable of protecting the administration that undertakes them, the organisations and its customers.

Cybersecurity, therefore, should not be considered a mere design requirement, but, like the others, a real objective to be achieved, as repeatedly stated by the European Commission and Article 25 of the GDPR, which introduces the concepts of security by design and security by default.

Unfortunately, no one can feel immune from attacks: Unidata understands safeguarding its IT systems is the basis from which to implement effective corporate security policies, both for small and large companies, as well as a direct manifestation of social

responsibility. For these reasons, the company has decided to put the provision of cybersecurity services at the centre of its challenges for 2022.

The objective of the services offered by Unidata is to provide its customers with Organisational, Procedural, Technical and Technological systems aimed at monitoring, managing, and maintaining security in the company to raise awareness and improve knowledge of it, making people understand the risks and quantifying the economic aspect. These are fundamental and enabling elements for the dissemination of the culture of data and its security in all its life stages.

Unidata, thanks to its IT infrastructure and technical and technological know-how, intends to set up, with the help of specialised partners, environments and teams dedicated to the monitoring and management of incidents in the areas of physical and perimeter security, network security and cyber security. This includes the creation of three types of control rooms:

- SOC (Security Operation Centre)
- NOC (Network Operation Centre)
- CERT (Computer Emergency Response Team)

The SOC/NOC/CERT service package addresses the need to ensure a level of security that reduces the main risks to which an organisation is exposed. A security-by-design and security-by-default approach enables companies to increase their competitive advantage, ensuring a reliable market profile and allowing access to tenders and contracts with certain security requirements.

Unidata implements targeted and punctual actions of:

- monitoring and management of events and incidents in the areas of physical and perimeter security, network security and cyber security;
- drafting and updating management systems, processes and procedures in the areas of Security Governance, Risk Management and Compliance;
- dissemination of a safety culture by defining roles and responsibilities and providing awareness and training sessions.

Aiming to improve not only the security of its own IT systems but also that of its customers, spreading its expertise in the area and making them aware and informed about this renewed cybersecurity challenge.

#### Unidata's internal information security

As emerged from the corporate risk analysis, data security is also a concept of particular importance within the structure itself.

The issue in question represents a threat with a very high level of impact, as any non-compliance with the relevant regulations would result in serious criminal and administrative penalties.

#### *On the processing of personal data Unidata:*

- ensures its users and suppliers the protection provided by European legislation, i.e. EU Regulation 2016/679 called General Data Protection Regulation or GDPR;
- makes the general information on the terms of the processing carried out in compliance with the applicable regulations available in the specific 'Privacy' section of the website **www.unidata.it**;
- adopts appropriate physical and logical security measures also in relation to the

acquisition, archiving and processing of personal, sensitive, and judicial data as well as telephone and telematic traffic data. Filing is provided for the fulfilment of the so-called compulsory justice services pursuant to Article 96 of the Electronic Communications Code;

- ensures full compliance with the new regulatory provisions on 'data portability' and 'right to be forgotten' contained in the GDPR

It should be noted that only one complaint was filed during 2022, which was handled successfully, concerning a user who was unable to remove his e-mail address from a newsletter. This report pointed to an anomaly in the newsletter which was promptly resolved.

In order to avoid the occurrence of further customer complaints and to ensure greater compliance with disclosure obligations, the company aims to strengthen publications and communications on the processing of personal data, on the company's web channels and website.

#### *In the field of Information Security, Unidata:*

- constantly ensures the availability of a so-called 'telephone fraud prevention' system aimed at protecting end users from any unlawful and improper use of the telephone service;
- adopts a specific procedure aimed at the possible management of abusive data access events (so-called Data Breach) pursuant to the regulations issued by the Garante Privacy;
- adopts an Information Security Management System that conforms to the standards set out in ISO/IEC 27001, with extensions 27017 (cloud services) and 27018 (Personally Identifiable information in cloud services);

- acquired AGID cloud computing certification as a provider of cloud services for the PA;
- constantly handles reports from national Cyber Security bodies, such as the current National CERT (Computer Emergency Response Team) set up at the Ministry of Economic Development;
- has structured, for the security purposes set out above, in its functional organisa-

tion chart, two distinct inter-departmental services deputed to intervene in the event of events and/or incidents occurring to the physical and/or IT service infrastructures. During 2022, no IT incidents involving personal data breaches or incidents subject to mandatory Data Breach reporting were recorded. In order to maintain the positive trend in this area, Unidata has planned to update the operating systems of devices for specific use.

GRI 102-16

## 2.9 Customer focus

### The organisation that can satisfy its customers survives.

As is well known, customers have become increasingly selective in their choice of brands in recent years. Winning companies are those that, in addition to providing a service that meets expectations, treat their customers with respect and have built a relationship with them that lasts over time. Listening and collaboration are, not surprisingly, the two key principles at Unidata for managing ongoing relationships with consumers and the associations that represent them.

Unidata is aware that developing a greater awareness of the importance of customer centricity plays a key role in business growth, and the starting point lies in shifting the focus from its products and services to its customers and their needs.

This approach resulted in the drafting of a Service Charter<sup>8</sup>, i.e. the document describing the standards of the services provided and

the rules of the relationship between Unidata and its customers, in order to protect their rights in the best possible way. The consumer protection information or Service Charter was drafted in accordance with the provisions of the Directive of the President of the Council of Ministers of 27/10/1994 on "Principles on the Provision of Public Services".

Through its Service Charter, Unidata sets out a series of quality parameters for the services it provides, which it is committed to guaranteeing, enabling customers to verify their effective implementation, and providing useful information for users to submit reports, proposals, requests for clarification and complaints.

By drafting and publishing this document, Unidata demonstrates that it bases its business on **customer relations** and not on pure transaction. This translates into the use of simple, non-bureaucratic language in communication to the public. Also, in order to guarantee the principle of choice, Unidata uses simple, clear and balanced procedures with reference to the stipulation of contracts

8 - [https://www.unidata.it/wp-content/uploads/2022/04/M7.1CS\\_Unidata\\_Carta\\_Servizi\\_2022.pdf](https://www.unidata.it/wp-content/uploads/2022/04/M7.1CS_Unidata_Carta_Servizi_2022.pdf)

A photograph of a man and a woman sitting together, smiling and looking at a document. The man is wearing a light blue shirt and the woman is wearing a pink shirt. They appear to be in a professional or collaborative setting. The image is partially obscured by a blue circle in the bottom left corner.

for the supply of services, withdrawal, and contractual modifications aimed at including, or excluding, the supply of an additional service or additional services.

The company ensures that the public is fully and clearly informed about the economic, legal, and technical conditions of service provision and undertakes to make use of the most appropriate means for communicating any changes to the aforementioned conditions.

The company's main commitment is to ensure that all information to users is provided in accordance with the principles of transparency, clarity, timeliness, and good faith.

### 2.9.1 From customer-oriented to customer-centric company

In this context, Unidata has initiated a digital transformation project to move from a customer-oriented to a customer-centric company. At the beginning of 2022, it started an assessment of the company's information systems. The assessment activity analysed Unidata's main dimensions such as organisation, customer contact channels and operational management. This made it possible to analyse what is currently available in terms of information systems about the processes served and the human and technological resources currently available for the provision of the services offered by the company. The objective was to bring out any potential and/or points for improvement and provide a list of possible interventions, alternative or sequential, needed to expand and improve the quality of services rendered.



During the period of analysis, it was generally evident:

- a good spirit of cooperation and problem solving
- an operational structure with medium to high skill levels
- some points for improvement.

The assessment revealed a spirit of good cooperation between operational structures with medium to high levels of competence.

More specifically, with respect to best practices also adopted in different industries, the need emerged to

1. introduce a CRM for both B2C and B2B channels
2. improve the current ticketing system
3. improve corporate reporting by introducing a business intelligence and KPI system
4. equip themselves with a knowledge base tool
5. to create a data culture and more speci-

fically to create a system for collecting information from the various systems, enabling the aggregation, structuring and certification of information

6. improve the customer culture, bringing the customer to the centre of the sales process

It also emerged that knowledge of processes and systems today is concentrated in the hands of a few people, who are very competent and well organised in their work.

Following the assessment activity, Unidata S.p.A. has initiated and is in the process of launching improvement actions that allow for greater efficiency in communication and work management. One of the first projects launched, and currently being released, is the adoption of the Microsoft 365 suite, which provides all employees with a series of collaborative and management tools that standardise working and interaction methods.

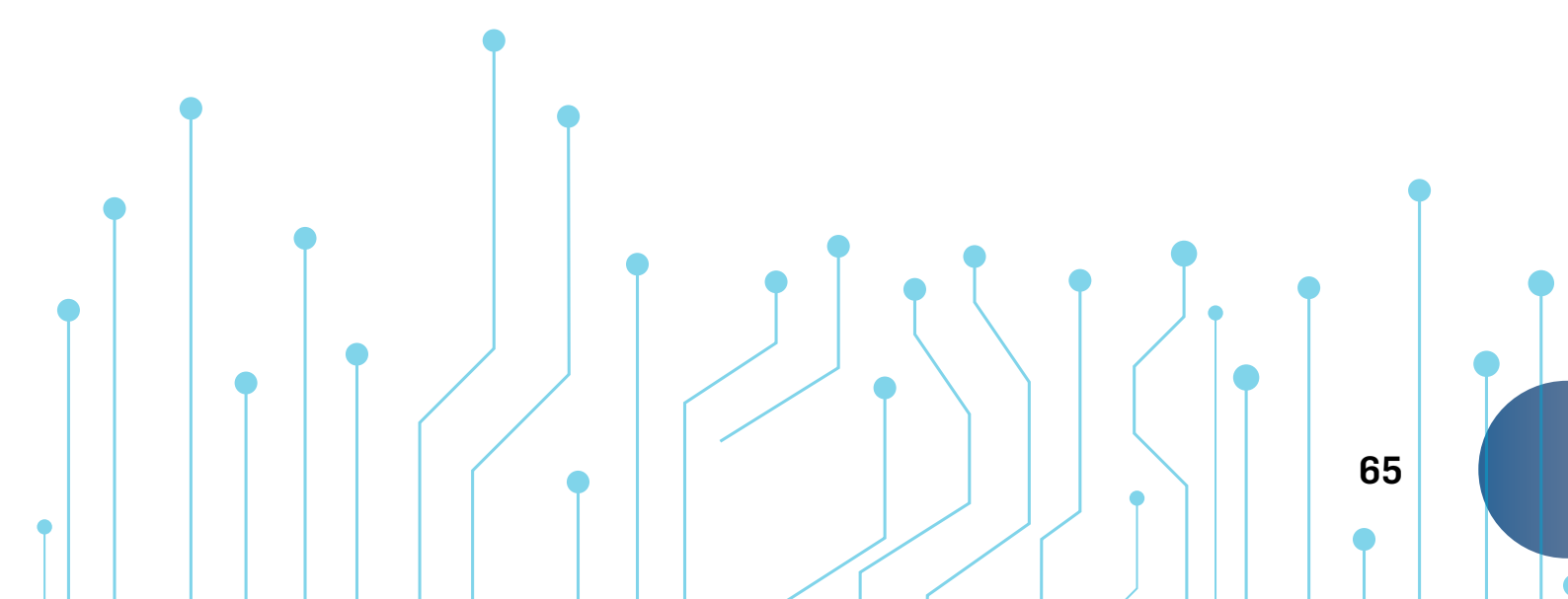



# THE ENVIRONMENT

3.1	The environmental protection approach	69
3.2	Compliance with environmental regulations	70
3.3	Unidata's initiatives for the environment	70
3.4	Energy efficiency: energy consumption and emissions	73
3.4.1	Direct Greenhouse Gas Emissions SCOPE 1	74
3.4.2	Indirect Greenhouse Gas Emissions SCOPE 2	74
3.5	Environmental risks	76
3.6	Research, Development and ICT Solutions for Sustainable Development	77

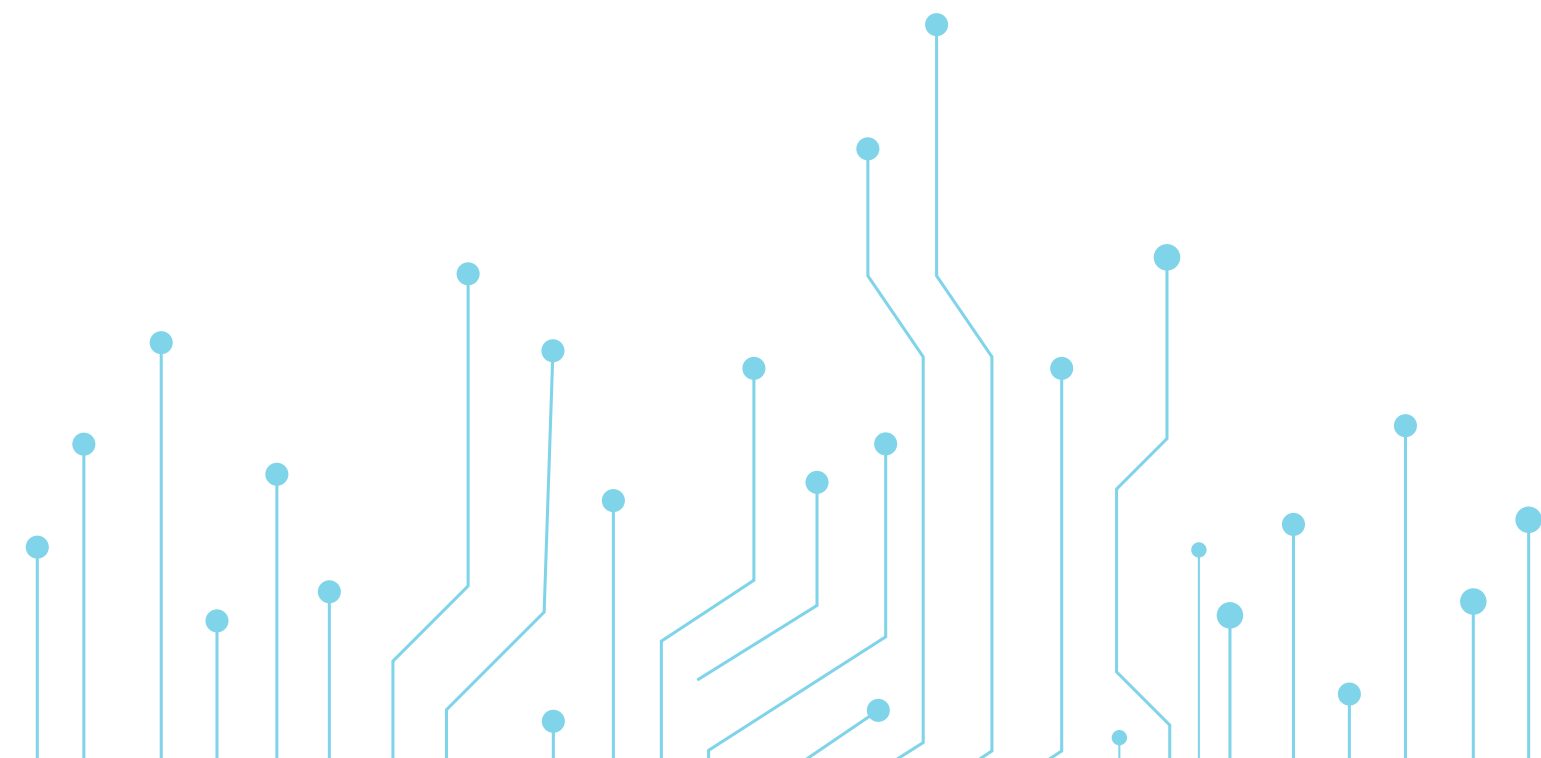



### 3.1 The environmental protection approach

Protecting the environment and natural resources, combating climate change and contributing to sustainable economic development are strategic factors in the planning, operation and development of Unidata's activities.

Environmental management is part of general management at Unidata, it deals with activities that involve the interaction of the company with the environment and the related issues take a central role in the company's strategies.

Unidata's responsibility for environmental protection is reflected in all phases of fibre-optic construction, which is carried out in compliance with the numerous regulations in force regarding land protection.

Optical fibre is a sustainable means of data transmission, unlike networks built from copper cables, the latter contributing significantly to emissions from fossil fuels. The copper network has electromagnetic losses and, due to its susceptibility to climatic events, requires continuous maintenance, with the consequent need for excavation and waste production.

'Full fibre' infrastructures, unlike copper ones, do not require energy when they are used for transmission, requiring less maintenance and, therefore, less impact on the environment. Optical fibre cable, with its flexible filaments and high conductive capacity, does not produce losses and rarely fails.

The strategy adopted by the company is geared towards respect for and protection

of the environment and the territory, as key factors in any ethically responsible business activity.

In addition to the ultra-fast fibre optic network service offered, cloud computing is also an environmentally friendly technology. Cloud computing plays a key role in the reduction of greenhouse gases, helping to bring digital technologies to a 15% decrease in global emissions. In the future, it is expected that connectivity will increasingly be a key factor for many of the 'virtuous' climate solutions, i.e. those capable of generating 'exponential effects' on greenhouse gas reduction, leading digital technologies to drastically counteract emissions that are deleterious to our Planet.

Unidata also looks with particular care at the use of plastic and at the use of disposable plastic, which is the most polluting and most difficult to dispose of. The company has in fact decided to adopt an internal policy aimed at '*Plastic Free*'.

Among the actions taken are:

- the replacement of plastic bottles with glass bottles;
- the choice of products packaged in glass or aluminium;
- preference for biodegradable products.

As far as waste is concerned, Unidata does not dispose of it directly, but pays equal attention to those who carry out ecological activities. At the '*Commerciti*' wholesale centre, where the company's headquarters are located, waste disposal takes place in a centralised and certified manner, both about spent printing toners and waste wood.

### 3.2 Compliance with environmental regulations

Pursuant to Article 25(3) of the Electronic Communications Code, the provision of electronic communications networks or services to the public is subject to a general authorisation obtainable by submitting a declaration of commencement of activity, provided that the prerequisites and requirements of the applicable legislation are met.

Unidata strives to eliminate or minimise, where feasible, negative impacts on the ecosystem that may be generated by its activities. This is also evidenced by its compliance with the UNI EN ISO 14001:2015 (*Environmental Management*) standard for which certification has been obtained.

The above certification ensures that activities are carried out effectively and directed towards the achievement of the set objectives, including:

- control and minimisation of environmental

impact, considering the context in which the company operates, its processes, products and services;

- efficient, rational and conscious use of resources;
- reduction of waste (energy, resources and materials);
- reduction of waste and emissions;
- compliance with environmental legislation.

Unidata is committed, in line with the National Climate Change Adaptation Strategy, to maintain and, possibly improve, the resilience and adaptive capacity of natural, social, and economic systems and to assess the opportunities arising from new climate conditions.

The Code of Ethics and the Company Organisational Model are structured in compliance with the general principles aimed at safeguarding the environment, containing provisions reserved for the prevention of the risk of offences ex. Legislative Decree 231/01.

### 3.3 Unidata's initiatives for the environment

Below are the actions implemented by Unidata to limit the impacts of its activities on the environment.

#### Energy Efficiency measures

The challenge of the new fibre network is to ensure data transmission reliability and **energy savings** at the same time.

During 2022, Unidata continued to work along the lines (renewable energy and energy efficiency) already identified in the past year, to make the most of the company's energy potential to contain consumption and a

progressive *green* transition.

The gradual replacement of copper with fibre and its penetration together with the development of 5G networks over ever larger areas will lead to the achievement of considerable energy savings that will benefit the entire region and the country.

Unidata will contribute to the achievement of national targets for increasing energy efficiency, as well as to an important infrastructural technological advancement for the telecommunications sector.

The challenge of the new fibre network is to



ensure data transmission reliability and **energy savings** at the same time.

#### Renewable energy

The directive for energy efficiency in Italy was introduced with the UNI CEI EN ISO 50001:2011 standard 'Energy management systems - Requirements and guidelines for use', which lists the minimum requirements that a system must have.

Unidata's photovoltaic system covering the large surface area generates clean energy that is used to offset part of the facility's needs.

Among its short-term goals, Unidata decided to replace its photovoltaic system in order to upgrade the plant and double the energy produced.

#### Energy intensity ratio

Energy intensity, as an indicator of the organisation's energy efficiency, relates the amount of energy consumed to the amount of energy produced internally. In 2022, this ratio will be around 3%. It should be noted

that in 2022 the value is halved compared to the previous year due to the increase in consumption caused by the full operation of the data centre (at the end of 2021 an entire rack island was unused). In addition, by closing off the cold aisles of the data centre at headquarters (Viale A. G. Eiffel) and the one in San Martino della Battaglia with plastic material (as a thermal insulator), we would drastically limit the mixing of cold air (coming from the air conditioners located in the data centres) and hot air (coming from the servers themselves) in order to reduce the related energy consumption by a value that we expect to be between 10% and 15% compared to the current ones.

Through the electricity supplier of its premises, Dolomiti Energia S.p.A., Unidata certifies the energy consumption in its bills, contributing to a measured reduction of CO<sub>2</sub> emissions.

Dolomiti Energia S.p.A. thanks to the "100% clean energy Dolomiti Energia" certification service makes its products eco-friendly. The certification is based on the feeding

into the grid (through the cancellation of GO certificates) of an amount of renewable energy equal to the company's energy consumption.

## Unidata is also active on several environment-related projects:

### ● Smart Water Metering in Gavi

The innovative **Smart Metering** solutions, which are part of the **Internet of Things (IoT)** project series, aim to correctly monitor consumption to draw up a **water balance** and identify **any leaks**.

The first deployment of the Smart Water Metering solution took place in Gavi in 2020.

Unidata has created, in collaboration with Gestione Acqua, a LoRaWAN™ network that allows remote reading of Itron smart water meters, enabling the efficiency of the water network managed in the municipality of Gavi. Following the success of the project in Gavi, Unidata successfully participated in a tender in 2022, through the Temporary Grouping of Companies (RTI) formed together with BIP S.p.A. and Lektor S.r.l., to be awarded the contract for the implementation of the water consumption monitoring system for the City of Palermo.

The introduction of new IoT technology is aimed at limiting waste for **sustainable** water resource **management**, ensuring that the infrastructure and energy used is effectively administered and supervised.

### ● Smart City: Unidata and TreeVoice for tree monitoring at Verano

In the Verano Monumental Cemetery in Rome, a tree monitoring project was born. Thanks to Unidata's LoRaWAN® network and the

enterprising start-up *TreeVoice*, an innovative system has been developed that is able to assess the stability of trees through several devices that transmit data on tree movement. The aim of the experimentation is to provide information to reduce the risk of damage related to falling trees through the acquisition of certain key parameters that are detected by means of a specific device installed on the tree trunk. The data collected is then transmitted via LoRaWAN technology through Unidata's network and then passed from Unidata's cloud to TreeVoice's application server, which processes the data and ensures continuous monitoring, promptly reporting any anomalies.

### ● Unidata at ENLIT Europe with the Botanical Garden of Rome project

Unidata, in collaboration with 'Sapienza Università di Roma' and 'Tektelic' - a company selected by the *LoRa Alliance*, presented the Orto-Botanico project at the Enlit Europe Milano event.

The event focused on enterprises, start-ups and companies that have implemented projects to preserve energy and our planet, for a more eco-sustainable future.

The aim of the project presented was to use LoRaWAN® technology to create an indoor and outdoor monitoring system of the floristic varieties present in the facility. The need was identified for a system capable of mapping the plants present, tracking weather forecasts, controlling soil parameters, and monitoring water consumption to avoid wastage, integrating everything on a single dashboard, so as to make data reading more immediate and optimised.



### 3.4 Energy Efficiency: Energy Consumption and Emissions

Unidata's operations are guaranteed by the use of energy from both renewable and non-renewable sources.

Unidata's fleet of cars required for business activities, inspections and installation and maintenance operations consists of 56 cars divided as follows:

	Petrol	Petrol Hybrid	Plug-In Hybrid	Diesel Hybrid	Diesel	LPG	Methane
<b>2021</b>	3	-	-	-	30	9	2
<b>2022</b>	3	32	1	1	12	4	2

Table 16 - Composition of Unidata's car fleet

As regards the electricity consumed within the premises for lighting, powering office equipment, heating, cooling the premises and for powering the Data Centres, this is partly produced indoors by the photovoltaic plant

owned by Unidata, and the remainder is supplied by the company Dolomiti Energia S.p.a.

Unidata's consumption divided into Renewable and Non-Renewable Sources is shown below:

Type	Interior		Exterior	
	Branch Data Centre	Generator sets	POP	Car Fleet
<b>Non Renewable Sources</b>	Diesel fuel (lt)			
	Petrol (lt)			4.044,30
	Diesel (lt)			19.533,35
	LPG (litres)			689,96
	Methane			4.677,47
	Hybrid Petrol			22.565,08
	Hybrid Diesel			2.503,03
	Plug-In Hybrid Benz			3.364,07
<b>TOTAL</b>	<b>135.348</b>	<b>-</b>	<b>82.543</b>	<b>57.377,26</b>

Table 17 - Unidata consumption from non-renewable sources

Among the non-renewable energy sources, the company uses diesel as fuel both for the car fleet and for powering the gensets within the infrastructure. It should be noted that the amount of energy used by the gensets is closely linked to their utilisation; they

only come into operation in the event of an emergency or if the electricity supply is interrupted. In the year 2022, the genset tanks were not refilled. In fact, 1200 litres were consumed - already in the tank - remaining from the refuelling counted in 2021.

Type		Interior		Exterior	
		Office & Central Data Centre	Generator sets	POP	Car Fleet
Renewable sources	Photovoltaics (KWh)	85.920			
	Green Energy (KWh)	2.303.948			
<b>TOTAL</b>		<b>2.389.868</b>			

Table 18 - Unidata consumption from renewable sources

The energy generated independently by the photovoltaic system positioned to cover the company's outdoor car parks during the year 2022 amounted to 85,920 KWh, clean energy that covered approximately 3% of the facility's total consumption.

In the light of this data, it was found that the current solar system is no longer as efficient (i.e. the current produced is not adequate for the same solar irradiation, as the panels have suffered degradation or damage from weathering) and will therefore be completely replaced during 2023 with panels that will be monocrystalline from amorphous (the current ones). This drastic replacement will mean an expected efficiency gain of around 20%.

### 3.4.1 Direct Greenhouse Gas Emissions SCOPE 1

The emissions counted derive from the use of fuels for heating and cooling the premises, emergency generators and the car fleet.

Considering these values, we can highlight how emissions per kilometre have decreased even though the kilometres travelled have increased significantly. It should be noted that 60 per cent of the diesel cars were replaced with plug-in/hybrid solutions and, despite the fact that an additional 12 vehicles were purchased, the emission value per km dropped from 125.15 g/CO<sub>2</sub> to 120.54 g/CO<sub>2</sub>, which supports the validity of replacing cars with more sustainable models.

Scope 1 greenhouse gas emissions also include inert fire gases, which do not emit greenhouse gases.

### 3.4.2 Emissioni Indirette di Gas Serra SCOPE 2

With reference to the Company's headquarters, the indirect greenhouse gas emissions of Scope 2 were eliminated through the use of the photovoltaic system and the use of totally green energy by the supplier Dolomiti S.p.a.

Through the supply of energy by Dolomiti S.p.A., Unidata saved the environment an impressive 648,496 kg of CO<sub>2</sub> for the entire year 2022.

The only indirect emissions of Scope 2 were generated by the consumption of electricity from non-renewable sources, related to the use of external POPs and the Data Centre of the branch office.

Direct Greenhouse Gas Emissions SCOPE 1			
Kg Co2			
	2020	2021	2022
<b>Generator sets</b>			
Fuel	132,5	530	3.180
<b>Heat pumps</b>			
Fluorinated	321,2	547	547
<b>Car park</b>			
Petrol	21.310	8.276,76	8.954,08
Diesel	120.828	97.701,79	59.225,41
LPG	25.111	28.592,68	14.291,50
Methane	-	3.799,00	8.444,80
Hybrid Petrol	-	-	71.363,58
Hybrid Diesel	-	-	6.528,20
Plug-In Hybrid Benz	-	-	3.101,23
<b>Total Car Park</b>	<b>167.250</b>	<b>138.370,23</b>	<b>171.908,80</b>
<b>Fire-fighting gas</b>			
Inert Gas	0	0	0

Table 19 - Direct GHG Emissions

Direct Greenhouse Gas Emissions SCOPE 2			
Kg Co2			
	2020	2021	2022
<b>PoP &amp; Data Centre branch office</b>			
Electricity	42.627	56.882	76.579
<b>TOTAL Scope 2 emissions</b>	<b>42.627</b>	<b>56.882</b>	<b>76.579</b>

Table 20 - Indirect GHG emissions

### 3.5 Environmental risks

Among the various risks Unidata encounters, the environmental ones concern:

- **Risks related to the energy consumption of the infrastructure used**

The exponential increase in data traffic is one of the key environmental challenges for the telecommunications sector. The transmission of data requires an ever-increasing amount of electrical energy, which has an impact on increasing consumption and indirect CO2 emissions into the atmosphere.

This risk is mitigated by Unidata's decision to power its Data Centre with totally *green* energy from renewable sources.

The **Integrated National Energy and Climate Plan 2030** is the national tool that marks the beginning of the change in our country's energy and environmental policy towards decarbonisation. The main target set is the reduction of greenhouse gas emissions and Unidata supports this goal by trying to reduce its emissions as much as possible.

Also, in line with the European Green Deal, supporting the achievement of climate neutrality by 2050, Unidata has defined its own energy saving strategy, its commitment to the use of renewable sources and the implementation of measures to control its emissions and environmental impacts.

- **Risk of incurring sanctions or measures for non-compliance with environmental regulations**

This risk is understood as the risk of non-compliance with the regulations in force concerning electromagnetic and/or acoustic emissions, environmental protection, location of posts and town planning.

Unidata monitors and is committed to

mitigating this risk through constant monitoring activities, carried out by the network design managers and the legal department.

In this regard, Unidata has taken steps to acquire UNI EN ISO 14001:2015 certification to formalise its commitment to compliance with sector regulations and the development of self-control methods aimed at continuous improvement of its performance.

- **Risks related to natural disasters (cloudbursts, earthquakes, floods, etc.).**

One of the main orientation criteria of the sustainability policy is the reduction of environmental risks. Particularly relevant is Natural Risk, understood as the product between the probability of a potentially dangerous natural phenomenon occurring and the economic value of the facilities on the territory itself. The frequency of such disasters is increasing due to Climate Change, with the manifestation of extreme events that impact, directly or indirectly, on the safety of production facilities and workers.

Such an unpredictable scenario makes it essential to adopt an adaptive behaviour: for Unidata, each catastrophic event represents a *lesson learned* from which to strengthen design techniques and preventive measures aimed at making the plant park resilient.

With this in mind, the method and information extracted from ex-post analyses of events that enable the definition of processes and practices for the mitigation of similar events in the future play a crucial role.

- **Risks associated with construction excavations for the construction of infrastructure in protected areas.**

### Plans required for environmental restoration and rehabilitation

To reduce the invasiveness of interventions in cities, but especially in protected territories, the Systems responsible for the excavation and rehabilitation phase will use the most environmentally sustainable procedures and technologies currently available.

In particular, reference is made to traditional mini-trenching and reduced mini-trenching, which efficiently and innovatively minimise

both environmental impact and inconvenience to the community; specifically, 'no-dig' techniques will be applied if the infrastructure permits.

This type of procedure is designed for the laying of pipes and cables underground, including the rehabilitation of existing infrastructure. These are, in any case, indirect risks that can be traced back to the contracts awarded to external Systems.

GRI 102-15

## 3.6 Research, Development, and ICT Solutions for Sustainable Development

Unidata, since its beginnings, has always kept pace with technological transformation, aware of the fact that we are experiencing a period of continuous change and transformation, especially in the field of telecommunications. The phenomena are manifold, and the consequences are significant; many technologies are changing and with them the structures: innovation, today more than ever, drives Unidata to study, update and persistently invest.

**Unidata** has also been involved in international research and development projects for some time, increasing its *know-how*; about artificial intelligence and *edge computing*, the agreement signed with **Bridge129** and **Ttm Technology** reinforces and confirms the company's vision that the way to offer innovative and sustainable solutions always passes through collaboration between different realities.

The exploration of the **Edge A.I. vision** world continues, the **Error. Invalid hyperlink reference**, applied to autonomous vision systems;

The group composed of Bridge 129 and Renewia, with the support of Unidata, is developing advanced and innovative solutions to digitally manage parking spaces reserved for people with disabilities. The system, which involves the use of a device that is installed and anchored to the ground at each reserved parking space, has already been tested in the centre of Rome for more than 150 reserved parking spaces, and recently also in Genoa, where Unidata has implemented a collaborative and effective solution for collecting data from parking sensors.

As previously mentioned, Unidata has taken on the role of principal in the Temporary Purpose Association (ATS) of the Rome Technopole Foundation and will operate within the 'Applied Research and Research and Innovation Infrastructures' Spoke. The company, in fact, will share its expertise and digital infrastructures (IoT and Artificial Intelligence, Cloud Datacenter and High Performance Computing) with its partners and the territory, contributing to Applied Research and Innovation activities related



to environmental sustainability and the saving of primary resources (Water and Energy) in the infrastructure and building automation sector. Unidata has also chosen the LUMSA University and the degree course in “*Information Technology Techniques for Data Management*” to support the university training of young people in the IT and digital field, by providing the most deserving students with a scholarship to cover the academic course.

The **FRAGILE** research project, of which Unidata was lead partner, came to an end in 2022. The main objective of the project was to develop an innovative teleassistance system with home automation support for people with chronic diseases, disabilities, but also for those living in isolated situations or for elderly people who need remote support.

The technology behind this system uses **environmental IoT sensors** to record different types of data within the flat where

people live: the use of the various rooms in the house, cleaning and sanitation, and the quality of sleep and rest. This data is processed by an **AI-based** system that generates synthetic macro-indices on quality of life and sleep, home microclimate and sanitation.

The project was also designed to give support to social service cooperatives and the experimentation was carried out together with Confcooperative Lazio Sud to reduce the social isolation of the frail person, prevent falls and pressure injuries and the hospitalisation of diseases that can be treated at home, without neglecting the assessment of the assistance provided to the patient by carers, domestic helpers, etc. in terms of personal and environmental hygiene, home comfort and ventilation.

With the start of the implementation phase, the ‘ELEGANT’ project, funded by the EU within the framework of the Research and Innovation actions of the Horizon 2020

programme, in which Unidata is the only Italian industrial partner, has now come into full swing.

The project, called **ELEGANT** (sEecure and seamLess EdGe-to-cloud ANalyTics), involves 11 partners from 8 European countries with prestigious research centres (including Italy's CNIT) and industrial partners (such as Austria's KTM Innovation).

Considering that currently, in IoT/BigData/AI systems, there is a clear separation between the physical devices and the cloud part of BigData and artificial intelligence, ELEGANT's solution aims to create a continuous loop between devices and BigData/AI, enabling the central system to dynamically distribute intelligence and data analytics capabilities even to low-cost heterogeneous peripheral objects (IoT network concentrators and devices).

To achieve this, ELEGANT aims to study and develop innovative methods and tools designed to solve the problem of the ever-increasing complexity of software technologies required to create and distribute intelligence in an 'EdGe to cloud' process.

The application areas and industrial use cases are automotive, health, smart metering, and video surveillance.

In the ELEGANT project, Unidata will focus on LPWA LoraWan networks, with particular emphasis on using the project results to increase the security of IoT networks, reduce the energy consumption of systems and optimally manage the radio spectrum. The case study chosen by Unidata to validate the

results will be the smart metering of water consumption.

Within the organisation itself, the company set up a working group (**Unidata Lab**) made up of young graduates, led by a fully dedicated figure, engaged in the study, testing and development of wireless technologies suitable for the Internet of Things (IoT).

Among the various technologies available for this kind of solution, Unidata has chosen to focus and dedicate its attention and investment specifically on LoRa™ technology and the related LoRaWAN™ network standard. This innovative technology allows, thanks to profound specific advantages - such as, for instance, a wide range of coverage, extremely long battery life, bi-directional data transmission and significant deep indoor penetration - to make the countless IoT solutions a concrete and truly cost-effective reality.

Unidata is also among the 250 companies that will participate in the ESG Lab. The new project is the brainchild of Intesa Sanpaolo in agreement with LUISS University and the Chamber of Commerce of Rome. The initiative will aim to support companies in environmental, social, digital and governance transition processes in line with the objectives of the PNRR.

The ESG Workshop represents not only a moment of encounter and comparison with other 'sustainable' companies but is also an opportunity that offers interesting stimuli for improving existing projects and continuing to develop new investments in terms of ethical and moral commitment.





# THE SOCIAL

4.1	Social Sustainability Measures	83
4.2	Social and Community Risks	86
4.3	The Organisational Structure	89
4.3.1	Staff Composition	90
4.3.2	Diversity and Equal Opportunities	91
4.3.3	Employment and Turnover	92
4.3.4	Framing and Gender	92
4.3.5	Training and Development	93
4.3.6	Health and Safety at Work	94
4.4	The Supply Chain	96
4.5	Customer Satisfaction	97

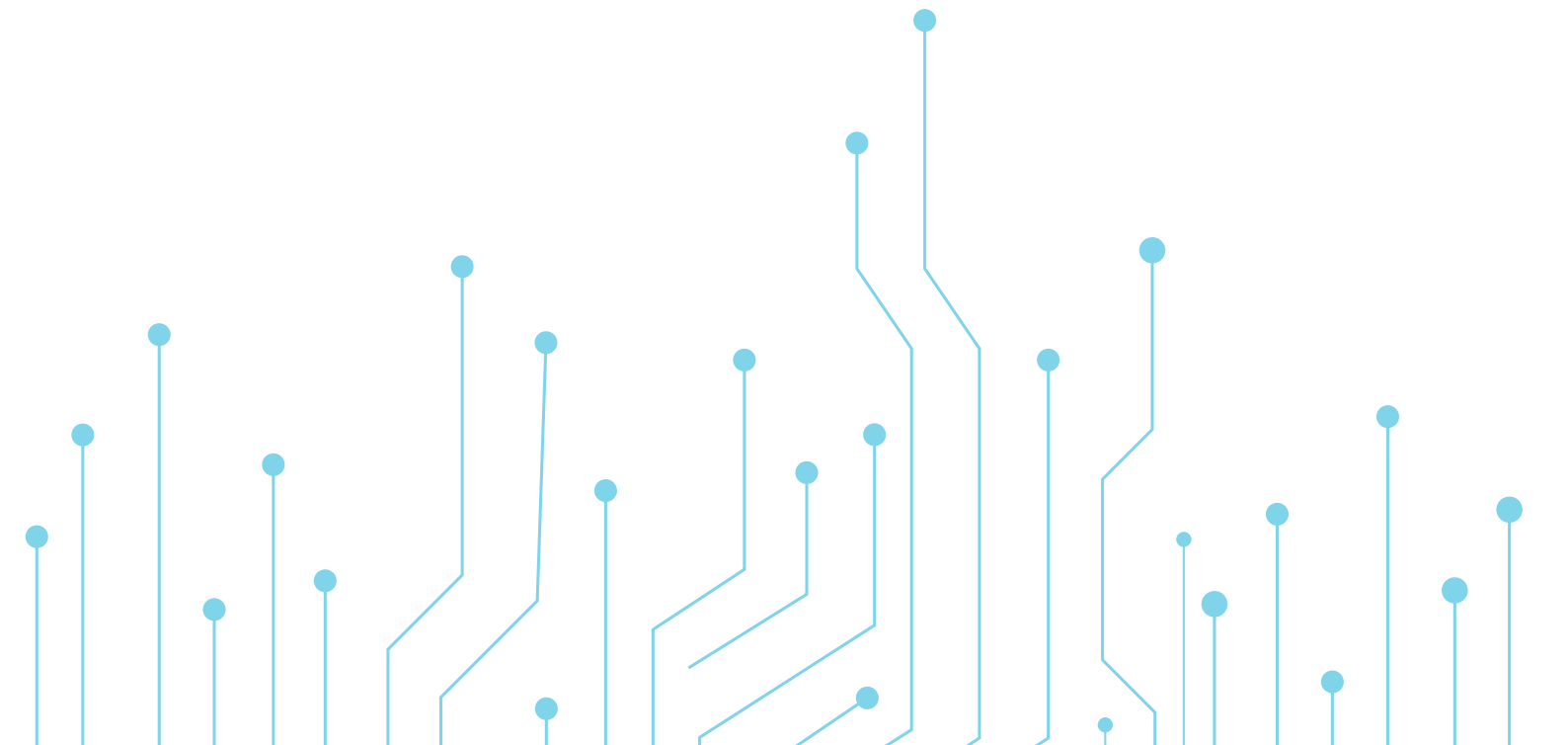



## 4.1 Social Sustainability Measures

**Social sustainability is one of the pillars of sustainable development.**

This concept, which underlies the circular economy, assumes that collective economic growth can be pursued without sacrificing the quality of life of individuals. Ensuring conditions of well-being, such as the respect of people's economic, social, political and cultural rights, is, in fact, a social responsibility that implies concrete actions, affecting macroeconomic systems and the relationship with the planet's natural resources.

For example, in the so-called developing countries, survival difficulties for populations are due to food insecurity resulting from climate change; in the so-called developed countries, on the other hand, social sustainability issues are linked to growing inequality between generations and the fight against racial and gender discrimination.

Depending on the context, therefore, social sustainability is seen as the set of actions aimed at achieving equity between categories of individuals, genders and generations.

**Unidata says no to any kind of gender discrimination: inclusiveness and respect are its cornerstones.**

With this in mind, decent working conditions are promoted, and gender equality is implemented, both in terms of pay and treatment of skills, with Inclusiveness as the foundation of economic and social choices.

Unidata also pays attention to its employees by guaranteeing flexible working with the introduction of one day a week of smart working per function and has accepted the request of the trade union representatives for the provision of monthly ticket restaurants.

As an Internet service provider, Unidata has always been at the forefront of overcoming the digital divide and, as a developer of the most important telecommunications systems, is a major player in the digital transition.

**Digital transition and digital divide are two different phenomena but with a common inclusive goal.**

Unidata demonstrates its social commitment by actively participating in various community initiatives:

- Since 2016, it has been collaborating with the Cuore d'Africa ONLUS association, an association that aids disadvantaged children and young people in Machakos, Kenya, through long-distance adoptions and the creation of an orphanage to house them. Unidata participates in initiatives such as collecting plastic caps for the 'Green Garden' project. And since 2019, it has been participating in the "Easter of the Heart" project, a fundraising initiative through the sale of Easter eggs, again in support of the "Green Garden" project, which stems from the need to make the Village of Hope self-sufficient, by expanding existing wells, connecting power grids, and creating water tanks; this project will create jobs for many families.
- Since 2020, it has been providing free fibre



and Wi-Fi connectivity to the capital's two prisons. Thanks to the Internet access services, at a time of great difficulty due to the Covid-19 emergency, inmates of the Rebibbia and Regina Coeli prisons have the possibility to communicate with their families also via Skype.

- Since 2018, it has been making its connectivity infrastructure available free of charge to the '*Great House of Peter Pan*', a reception centre serving children and adolescents with cancer and their families, created in Rome by the non-profit Peter Pan Association.
- Thanks to the partnership with the LUMSA University of Rome, it offers young students the opportunity to implement their knowledge and notions in the technology sector by granting merit scholarships and internships for students. It organises seminars, conferences and other initiatives aimed at illustrating and disseminating the culture of innovation and technology, such as in the exponentially growing field of IoT.
- In 2021, it co-financed and participated in

the renovation of the historic Piazza Brin in the heart of the Garbatella district. In the square, after the construction of the new street lighting system, the paving was renewed, the manholes and drains were repaired, thus solving problems related to rainwater disposal and giving the community the restyling of one of the most beautiful squares in the municipality.

- It is the official sponsor of the Totti Soccer School, which opened the curtain and presented the jerseys for the 2021-2022 football season.

During 2023, further initiatives are planned to strengthen the link with the community in which it operates and support the most vulnerable.

#### **UNIDATA WITH TWT**

Unidata's social responsibility extends beyond the perimeter of the company and involves, in addition to employees and shareholders, a wide range of stakeholders: business partners, suppliers, customers, public bodies and NGOs.



The acquisition of TWT, a company with an excellent reputation in the market, is not only an excellent way for Unidata to accelerate growth and increase its competitiveness in the market, but also an opportunity to create social value.

Expanding the social dimension of sustainability in a company has a significant impact on all aspects of its organisation. Creating sustainable relations with all stakeholders in the company's business and combining economic responsibility with social responsibility will lead to the promotion of values shared by the company and the people for the protection of the territory and the environment. Over the years, the TWT Group has placed greater emphasis on community development, launching important initiatives, which are listed below:

- **It supports the Save the Children** association by supporting the 'Let's rewrite the future' campaign in favour of the children and families most in difficulty in Italy following the spread

of the Coronavirus, and the non-profit organisation Wamba and Athena association that supports children suffering from SMA (spinal muscular atrophy), guaranteeing over two months of psychological assistance to the little ones and their families.

- It finances an artistic and social project, aimed at raising people's awareness on the issue of plastic pollution in water, which started on 25 July 2019 with the launch of the work *Pesce Tanica* by Federico Clapis at sea (Mediterranean).
- It adheres to fundraising campaigns for socially useful purposes through the 455XY solidarity numbers, as per the Self-Regulatory Code for the management of solidarity numbers signed together with the other main national operators. It is a project born in 2014, when the main telecommunications operators adhered to the Memorandum of Understanding with the Department of Civil Protection, defining a procedure for the immediate activation and timely distribution of

- solidarity numbers to raise funds for populations affected by natural disasters.
- Every year TWT participates in around 100 fundraising campaigns on various topics: scientific research, health care, personal protection, animal welfare and the environment.
  - During 2022, TWT reaffirmed its commitment to actively support projects for children during the outbreak of war in Ukraine. It participated in the extraordinary solidarity campaign on the number 45525 in favour of Unicef, UNHCR and the Red Cross to raise funds needed for the survival of those affected by and fleeing the hostilities, and to guarantee them quick and effective humanitarian assistance. The funds raised through this campaign were used to provide families and children in Ukraine with protection, shelter, medical care, drinking water, personal hygiene kits and psychological support.
  - In addition, in order to respond as promptly as possible to the serious emergency underway, in March 2022 TWT collected basic necessities (clothing, food, etc.) from its employees, which, through the Ukrainian Churches present in Milan, were delivered to families in difficulty.
  - TWT, which has always been socially aware, supports projects of non-profit associations and organisations, directly or together with its employees.
  - For Christmas 2022, TWT renewed its support for the Italian Association for the Fight against Neuroblastoma through a twofold purchase: Christmas cards for its customers and employees, and boxes of chocolates for employees and collaborators. The Associazione Italiana per la lotta al Neuroblastoma O.N.L.U.S. (Italian Association for the Fight against Neuroblastoma), founded in 1993 at the "G. Gaslini" Institute in Genoa on the initiative of some parents directly involved and oncologists who were treating sick children, has as its mission to defeat Neuroblastoma and Paediatric Solid Tumours through innovative research projects aimed at identifying new and effective therapies and personalised treatments.
- Unidata strongly believes that, through the collaboration of these two realities, it will be possible to guarantee a constant and capillary digitalisation of the country, proving to be an active part of responding to the needs expressed by the community.

GRI 102-15

## 4.2 Social and Community Risks

During the risk assessment, Unidata carried out a more in-depth analysis of possible social and community impacts to align its operations with the principles of social sustainability.

The significant risks to be monitored are:

- *Risks related to findings of non-compliance with regulatory regulations and changes in the regulatory framework.*

Regulations in the telecommunications sector, and in particular those relating to fibre optics, are constantly evolving.

The need for Italy to get back into the race on the broadband front is prompting institutions to speed up on the regulatory side, with a focus on simplifications for the laying of fibre optics. The new regulations, starting with Legislative Decree 33/2016 implementing European Di-

rective 61/2014 'Fibre Optics Decree', aim, in fact, to facilitate the installation of high-speed electronic communication networks by promoting the shared use of existing physical infrastructure and the use of new, less invasive, and less costly excavation technologies.

This orientation is confirmed by Decree-Law No. 76 of 2020, which introduced further simplification measures for the deployment of networks. The provision in question provides that companies providing electronic communications networks and services are allowed to carry out the excavation, installation, and maintenance of fibre optic communications networks by submitting only a certified start of activity (SCIA) report to the competent local administration and to the bodies responsible for carrying out controls.

Decree-Law No. 76 refers to the provisions of Decree-Law No. 18 of 2020, which allowed companies providing electronic communications networks and services to carry out all useful initiatives to upgrade infrastructure, ensure the operation of networks and the operability and continuity of services, including during the SARS-CoV-2 epidemiological emergency.

The need to meet European targets for broadband and ultra-wideband connections, which require the cabling of at least 50 per cent of housing units, is driving our country to invest in the development of fibre-optic infrastructures, turning new regulatory interventions into opportunities and not risks.

To prove the reliability of its services, the company makes use of certifications issued by third parties. In particular, Unidata has obtained ISO 9001:2015 Certification, relating to the quality of architectures, ISO 27001:2013, relating to the information security management system, and in 2021 obtained ISO 14001:2015 Certification, relating to the environmental management of organisations.

#### ● *Reputational and operational risks due to delays in project implementation*

Corporate prosperity is no longer based on purely financial parameters, but is closely linked to values such as reputation, brand, quality and quantity of intellectual capital, respect for the natural ecosystem and human and social rights.

Reputation is a determining factor in a company's success: the media, when certain events occur, have such a resonance chamber that they can cause reputational damage, which can generate a drop in profit volume and brand value. Unidata will be proactive with local communities to identify the most relevant needs, to be integrated into structured action plans, constantly monitoring their implementation in order to prevent reputational and operational risks.

As part of its operations, the Company is exposed to certain risks such as:

- Increased cost of supply of energy sources and/or other essential supplies;
- Difficulties in accessing raw material supplies;
- Unavailability of close substitutes with regard to purchases and supplies/single suppliers in the field of supply installation;
- Excessively long lead times for the administrative processes required to obtain authorisations from local administrations for the laying of new fibre-optic network lines;
- Excessively high costs for obtaining these authorisations and, in general, for the realisation of the network projects envisaged in the development plan.

The occurrence of the aforementioned circumstances could also jeopardise the outcome of the Company's existing or future investments, resulting in a decrease in their profitability compared to what was budgeted or in the loss of the invested capital.



● *Risks associated with the collection, storage and processing of personal data*

In carrying out its activities, Unidata collects, stores and processes the data of its customers, employees and suppliers, and is obliged to comply with the applicable statutory and regulatory provisions on the protection of personal data.

Even though Unidata has adopted security protocols aimed at avoiding certain critical issues, the Company is still exposed to the high risk of personal data being damaged, lost, or stolen, disclosed or processed for purposes other than those authorised by customers, even by unauthorised persons. The occurrence of the aforementioned events, also because of hacker attacks, would have a negative impact on the Issuer's business, in financial terms, assets and, with particular reference to Cloud services, in terms of reputation.

● *Workplace safety risks*

The company's business involves excavations, the positioning of antennas and cables, contact with electrical cables and other matters that may endanger the safety of its employees and collaborators.

Even though Unidata complies with the regulations in force on safety in the workplace, provides for personnel training programmes and adopts special precautions for the performance of the aforementioned activities, accidents in the workplace could occur, even significant ones. The occurrence of such events, in addition to the possibility of giving rise to litigation and damage to the company's image, could jeopardise the regular conduct of business with significant repercussions on the company's economic, financial and equity situation.



### 4.3 The Organisational Structure

Rapid technological changes, combined with the changes taking place in the world of work, have generated a profound impact on the overall management of companies. In a climate of great instability, one thing is certain: for each individual company, organisation, people, and roles will continue to play a central role in order to best meet the challenges imposed by these profound transformations.

In fact, a report by Vigeo Eiris, a leading European ESG rating agency, found that companies that are more virtuous in respecting workers' rights and that responsibly manage their supply chains and relations with their stakeholders are more resilient to the crisis and are able to seize more opportunities to deepen their ties with the community.

**Unidata has clearly defined the set of values it shares and pursues towards its resources, enshrining them in its Code of Ethics.**

Among the various values, the principles aimed at respecting and protecting the individual, as well as those relating to health and safety at work, are of fundamental importance. The policies practised in the management of human resources are marked by the enhancement of the personality and professionalism of each individual, in a working context inspired by the rejection of any form of discrimination or harassment.

In order to improve the internal cooperation and communication aspects and increase

the soft skills of its personnel, the company approved a strategic training plan for all the organisation's personnel in 2022. The assessment on the resources of the commercial area has already been concluded in January 2023, and will soon be followed by that on the key people of the first and second line.

The 2022-2024 training plan envisages maintaining existing skills within the organisational context, developing new skills, and upgrading existing skills to:

- Valuing human resources by promoting their personal development and increasing organisational well-being;
- increase, in human resources, awareness of their own contribution to the achievement of the organisation's objectives and strategies;
- support the overall growth of the organisation, the efficiency of processes and the quality of services provided;
- support functional competencies for the pursuit of new business opportunities.

In particular, the 2023 Plan envisages the analysis of training needs gathered over 2022 for each business sector and the preliminary assessment of skills for each worker to be involved in the project. The training will focus on the issues of digital transition and ecological transition, with priority given to the first aspect, with a total of 13,800 hours of training, which translates into about 130 hours of training per capita. Unidata is also committed to offering equal employment opportunities without discrimination based on ethnicity, gender, age, personal and social conditions,

religious and political beliefs, to ensure that its employees are treated fairly and meritocratically. The company ensures that its employees are not subject to any constraints arising from gender differences within their development and training paths.

In order to implement its commitments, the company renewed the so-called '**Charter for Equal Opportunities**' for 2022 as well<sup>10</sup>, an initiative promoted by the European Commission and sponsored by the Ministry of Labour and Social Policies, aimed at '*disseminating a corporate culture and inclusive policies, free from discrimination and prejudice, capable of enhancing talent in all its diversity*'.

#### 4.3.1 Staff Composition

Unidata's organisational structure underwent organic growth during the year and, as at 31 December 2022, consisted of 102 employees, of whom 78 were men and 24 women: the Quota Rosa within the structure thus stands at around 24% this year.

Within the total workforce, 90 employees are employed with a permanent contract and 12 employees with a fixed-term contract (of which 8 with an apprenticeship contract). In addition, 93 employees have a full-time contract, while 9 employees have a part-time contract.

The very high percentage - around 88 per cent - of the number of permanent employees in relation to the total number of employees shows how the concept of stable and lasting employment represents a fundamental element for Unidata, both as a motivational

force for employees and as an indispensable factor in economic growth and development.

Analysing the age distribution of the staff, it can be seen that 60% of employees are between 30 and 50 years old, 22% are over 50 years old and 18% are employees under 30 years old.

Finally, the presence of four workers belonging to the so-called protected categories should be noted.

With the opening of the new operational and commercial office in Bari, Unidata wants to take the opportunity to invest in and enhance the youngest segments of the population and develop specific high-tech skills together with them.

Aware that the younger generation generally demonstrates a more experienced approach to technology, their presence also bodes well for supporting new and emerging technologies within the organisation.

Unidata recognises that the appeal of new technologies to the younger generation can help the company benefit. With change constantly accelerating and the changing needs of customers, these younger workers will be able to help Unidata keep up with the times. The ambition is to create shared value by offering innovative services by opening an office with highly specialised staff.

Unidata is committed to harnessing the resources and bright minds in the area, working day after day to develop all the necessary components to achieve this important goal.

<sup>10</sup> - <https://www.cartapariopportunita.it/>

### 4.3.2 Diversity and Equal Opportunities

	2021			2022		
	Men	Women	Total	Men	Women	Total
Management	5	-	5	5	-	5
Board of Directors	5	2	7	5	2	7
Board of Auditors	3	2	5	3	2	5
<b>TOTAL</b>			<b>17</b>			<b>17</b>

Table 21 - Unidata's board composition

The organisational structure of the employees, on the other hand, is as follows:

Age	2021			2022		
	N. Men	N. Women	Total	N. Men	N. Women	Total
	69	21	90	78	24	102
<30 years	12	0	12	18	0	18
30-50 years	44	14	58	45	16	61
>50 years	13	7	20	15	8	23

Table 22 - Gender Diversity in Unidata

	2021			2022		
	Men	Women	General	Men	Women	General
<b>Average Age</b>	40	45	<b>41</b>	39	46	<b>41</b>

Table 23 - Average age of Unidata employees

### 4.3.3 Employment and Turnover

In 2022, 20 new employees joined Unidata's workforce, registering an entry rate

of 22%, while the number of outgoing employees was 8, corresponding to an exit rate of 9%.

#### ENTRY TURNOVER 2022

età	Men	Women	Total	% Turnover
<30 years	11	0	11	12%
30-50 years	6	3	9	10%
>50 years	0	0	0	0%
<b>TOTAL</b>	<b>17</b>	<b>3</b>	<b>20</b>	<b>22%</b>
<b>% Turnover</b>	<b>19%</b>	<b>3%</b>	<b>22%</b>	

#### TURNOVER OUTPUT 2022

età	Men	Women	Total	% Turnover
<30 years	4	0	4	4%
30-50 years	3	0	3	3%
>50 years	1	0	1	1%
<b>TOTAL</b>	<b>8</b>	<b>0</b>	<b>8</b>	<b>9%</b>
<b>% Turnover</b>	<b>9%</b>	<b>0%</b>	<b>9%</b>	

Table 24 - Incoming and outgoing turnover

The incoming and outgoing turnover rate is calculated as:

- ratio of the number of hires during the year to the average number of employees between the beginning and the end of the year;
- ratio between the number of resignations/ layoffs during the year and the average number of employees between the beginning and the end of the year.

Total turnover = (entrants + leavers in the period) / (average headcount in the period) = 31.1%.

### 4.3.4 Framing and Gender

The employment contract applied to employees is the National Collective Bargaining Agreement (CCNL) for the metalworking sector for workers in the private metalworking and plant installation industry, with the exception of the CFO to whom the contract for managers of service sector companies applies.

## INQUADRAMENTO (Breakdown by gender and classification)

	2021			2022		
	Men	Women	Total	Men	Women	Total
<b>Managers</b>	2	-	<b>2</b>	2	-	<b>2</b>
<b>Quadri</b>	2	-	<b>2</b>	3	-	<b>3</b>
<b>Employees</b>	55	21	<b>76</b>	63	24	<b>87</b>
<b>Workers</b>	10	-	<b>10</b>	10	-	<b>10</b>
	<b>69</b>	<b>21</b>	<b>90</b>	<b>78</b>	<b>24</b>	<b>102</b>

Table 25 - Breakdown by gender and classification

## INQUADRAMENTO (Breakdown by classification and age)

	2020				2021			
	<30	30-50	>50	Total	<30	30-50	>50	Total
<b>Managers</b>	-	-	2	<b>2</b>	-	-	2	<b>2</b>
<b>Quadri</b>	-	1	1	<b>2</b>	-	2	1	<b>3</b>
<b>Employees</b>	9	49	18	<b>76</b>	16	51	20	<b>87</b>
<b>Workers</b>	3	7	-	<b>10</b>	-	-	10	<b>10</b>
	<b>12</b>	<b>57</b>	<b>21</b>	<b>90</b>	<b>16</b>	<b>53</b>	<b>33</b>	<b>102</b>

Table 26 - Breakdown by classification and age

### 4.3.5 Training and Development

Staff training is an integral part of human resources management. It is, in fact, a series of activities that enable employees to train and grow professionally on the one hand, and the company to successfully achieve its business objectives, on the other.

Unidata pays considerable attention to the well-being of its employees, using continuous training programmes and by adopting a meritocratic remuneration policy.

In 2022, six professional training courses were held for subordinates, totalling 282 hours of lessons, in order to strengthen not only professional skills but also to enhance personal cultural background. The courses delivered covered the topics of: HR fundamental, Privacy, Legislative Decree 231/01, ISO 14001 and FLUKE cabling.

As part of its corporate welfare policies, to make its workers share in the excellent economic results achieved, the company

invested in production incentives for its employees, increasing the value to EUR 126,018 from EUR 106,210 in the previous year. Recognition of merit for a job well done is certainly the best way to stimulate each individual to enhance their work.

As planned in the previous year, to increase the value of the sums set aside and to guarantee its employees prosperous severance pays, Unidata decided to allocate the sums set aside as severance pay to a common investment fund.

#### 4.3.6 Health and Safety at Work

Safety in the workplace is fundamental and is independent of the type of company, its size or its sector. Without adequate safety measures, a company puts its workers, customers, brand reputation and revenues at risk.

Unidata protects the moral and physical integrity of its employees and collaborators, committing itself to spreading a culture of health and safety at work that tends to make staff aware of the risks related to their activities and to promote responsible behaviour.

All the safety measures required by technological developments are taken to ensure a safe and healthy working environment, in full compliance with current prevention and protection legislation.

The text that unites all the relevant legislation is the Consolidated Safety at Work Act, also known as Legislative Decree 81/2008, which introduced the subject of **risk assessment** as a '*fulfilment of absolute centrality*' and which '*must cover all risks to the safety and health of workers, including those concerning groups of workers exposed to particular risks*'.

The specific risks associated with the company and its workers are formalised in the risk assessment document (**DVR**). It must be constantly updated and contain:

- the risk assessment **report**, detailing the criteria used to assess it an **indication of the prevention and protection measures** implemented and the protective equipment used;
- an indication of the prevention and protection measures implemented, and the prevention devices put in place;
- the **programme of measures** that are to improve security levels over time, as well as the procedures for implementing the measures to be carried out, together with the roles within the company of those who are to deal with them. These can only be persons with the appropriate skills and powers.
- an **indication of the tasks** that may expose workers to **specific risks** and for which professional skills, specific experience, appropriate education, and training are required.

In line with the provisions of the Consolidation Act, on 6 June 2015 Unidata drew up the first Assessment Document dealing with the Risks associated with the Cabling and Maintenance of fibre optic networks already installed in manholes or in cabins along road networks. This document was revised and updated on 08 April 2021.

The Prevention and Protection Service Manager (RSPP) is Mr. Pietro Marco Picierro and the Workers' Safety Representative (RLS) is Mr. Maurizio Cosentino.

The activity of cabling fibre optic networks consists solely of the connection of data cables by means of fusion splicing machines that are



not connected to the power grid. However, the activity is considered particularly risky because the working environment - public roads, underground rooms with access to public roads, outdoor cabins located on pavements - influences the simplicity of the operations.

Number of Hours of Health and Safety Training for Workers	
2021	2022
88 hours	88 hours

Table 27 - Hours of health and safety training

Occupational health and safety training is of particular importance, also in relation to specific obligations provided for by sector regu-

lations. Therefore, in cases where it was not possible to activate videoconference methods to carry out compulsory training, training activities were carried out in presence, adopting appropriate measures to contain the risk of contagion.

#### Accidents at Work

An occupational accident, i.e. a **harmful event that causes damage to a worker's psycho-physical integrity** during the normal course of work, is mitigated by society in order to regulate occupational risk, i.e. that risk related to work.

Unidata protects the physical integrity of those who perform any activity for the company. No injuries of any kind occurred during the four-year period 2019-2022.

## 4.4 The Supply Chain

The process of selecting Suppliers or Systems is guided by the mandatory principles of transparency, economic efficiency, and compliance with applicable regulations.

The company requires its business partners to submit certifications on quality management, health and safety at work and environmental impacts. To successfully complete the accreditation process, all suppliers must sign specific clauses relating to environmental and social responsibility issues, which include compliance with applicable legislation, possession of the required authorisations, and the adoption of principles for the protection of workers' rights, with particular attention to the protection of internationally enshrined fundamental workers' rights.

Regarding the procurement procedures for the materials needed to build the infrastructure, Unidata noted, during the risk assessment process, the need to adopt dedicated policies for supply chain continuity and supply chain security.

The pandemic and the containment measures adopted to deal with the health emergency have imposed increasingly stringent limits on the movement of goods, people, and the conduct of production activities. Coordinated procurement activities and the identification of procedures for managing critical suppliers in emergencies can ensure business continuity even in the event of unforeseen events.

Unidata renewed its intention, shortly, to proceed with the qualification and subsequent evaluation of suppliers, not only verifying technical, economic and organisational quality requirements, but also analysing

compliance with environmental sustainability criteria.

This will involve the creation of a 'Sustainable Vendor Rating' system, i.e. a management process aimed at measuring the performance of suppliers and favouring the improvement of supplies with respect to environmental and social evaluation parameters while keeping the traditional ones unchanged.

As part of the Supply Chain Analysis, the following risks emerged;

### 1. *Risks related to joint and several liability in procurement contracts*

The procedures for assigning work to Systems are managed according to the procurement guidelines. In particular, the procurement contracts concluded by Unidata with individual suppliers are based on a Framework Agreement specifically designed and verified by the company's lawyers.

This agreement provides for the conclusion of various documents for the performance of the individual phases of the Contract, which are to be considered an integral part of the Contract, namely:

- A.** Framework Contract
- B.** Fostering Agreement
- C.** Letters of Assignment

The Framework Agreement envisages, at the time of its signature, the exchange between the parties of the technical-administrative documentation relating to the specific job order, pursuant to the provisions contained in Legislative Decree 81/2008 as amended and supplemented, Legislative Decree 163/2006 and other regulations applicable to the relations in question.

The stipulation of the Framework Agreement



also implies the suppliers' acceptance of the company's Code of Ethics. In this sense, Unidata undertakes to promote, within the scope of its procurement activities, compliance with contractual conditions consistent with its environmental policy and with the ethical principles contained in the Code of Ethics..

## 2. *Risks of incurring penalties, economic and financial losses as a result of a partial or total interruption of relations with specific suppliers or contractors*

Unidata selects its suppliers from those on its 'Vendor List'. For all suppliers interfacing with Unidata, an accreditation and monitoring

procedure is in place over time, which makes it possible to mitigate the risk of purchasing goods and services from suppliers that are unreliable or do not meet the legal requirements.

They are checked in advance, both with regard to their own economic and financial situation, and with regard to the absence of prejudicial facts concerning the Company, and are obliged to keep up-to-date the documents required for accreditation.

The risk of incurring penalties, economic and financial losses is mitigated by the wide availability of suppliers in the same category and thus easily replaceable in the event of a sudden or planned supply interruption.

GRI 102-29 103-01 103-02 103-03

## 4.5 La Customer Satisfaction

**Customer Satisfaction** is understood as the customer's perception that a company's offer system has met or exceeded his or her expectations, concerning the set of benefits and costs relevant to him or her in purchasing and using that offer system.

Customer satisfaction is the primary aim of Unidata as a strongly market-oriented company, whose efforts tend towards the development of an ongoing, stable and lasting relationship with customers, through the pursuit of satisfaction of their needs, desires and expectations. The basis of customer satisfaction is therefore the creation of value for customers, i.e. the satisfaction of their needs and requirements effectively and efficiently.

Unidata is well aware that from customer satisfaction springs customer loyalty. Customer

loyalty can be seen as a form of long-term investment that contributes to increasing positive word-of-mouth and, consequently, improving the brand image.

Customer satisfaction and customer loyalty have important positive effects, as a satisfied customer:

- hardly withdraw from the supply contract, ensuring the company a greater flow of sales over time;
- tends to increase and differentiate its purchases, also signing contracts for additional services;
- tends to be willing to pay a higher activation price for services or tends to apply less pressure for discounts.

As the economic data show, Unidata considers the welfare of its customers the engine of its growth.



CUSTOMERS	2022	2021	Var. YoY %
Business <sup>11</sup>	2.175	2.060	+5,58%
Consumer	14.247	10.453	+36,30%
<b>TOTAL</b>	<b>16.422</b>	<b>12.513</b>	<b>+31,24%</b>

Table 28 - Growth of customer base by business area

In the highly competitive telecommunications market and in times of deep crisis like the ones we are currently experiencing, a high level of customer satisfaction can make a real difference for Unidata. Constantly monitoring the level of customer satisfaction and taking daily action to improve it has become one of the strategic objectives of Unidata's marketing function.

A CRM (Customer Relationship Management) system is currently available in Unidata's commercial area management perimeter, which, supported by additional corporate IT systems, manages in semi-automated terms, the relational input/output of customers

both at the level of technical assistance/complaints (OTRS system) and at the service provisioning/delivery stage (Zeus, Jira and the contract signing portal).

To this end, in 2021 Unidata obtained UNI EN ISO 9001:2015 certification in the EA 28 and 33 sectors, i.e. for the conformity of the processes of 'Provision of Internet Access, Telephony and Data Centre Services (Cloud, Hosting, Housing, Co-location & Security Services)' and for the 'Design, Installation, Supply and Maintenance of Local Optical Fibre and Internet of Things Telecommunications Networks operating through various transmission media and different applications'.

11 - Business' includes: Micro business, Business, PA and Wholesale

ISO 9001 defines the requirements of a Quality Management System for an organisation. It represents the reference point for an organisation that intends to plan, implement, monitor, and improve both operational and support processes, designing and implementing the quality management system as a means of achieving its objectives. The customer and his satisfaction are at the centre of this system; every activity, application and monitoring of activities/processes is in fact aimed at ensuring maximum customer satisfaction.

Unidata will thus make its service more effective and efficient and strengthen its **customer loyalty**.

In this regard, Unidata has highlighted the need to provide for an overall review of operational processes, to consolidate the compliance of the service delivery cycle with the requirements of the UNI CEI ISO/IEC 20000-1 standard (Service Management System - SMS). It is believed that this overall review activity, in agreement with all the company's functional areas and in compliance with the requirements that will be formalised,

may allow for the improved re-definition of control points, monitoring tools and analysis and verification procedures that are more suitable for ensuring the operation of an adequate CSM and, also, to meet the need for a "near real-time" type of quality monitoring.

Among the objectives for 2022, there is therefore the introduction of appropriate tools for monitoring Customer Service KPIs, such as:

- Customer Satisfaction Score (CSAT, measures the value of customer satisfaction)
- Net Promoter Score (NPS, customer loyalty parameter)
- Average Call Time (TMC)
- Customer Retention Rate (Customer Loyalty Indicator)
- SERVQUAL (service quality framework)
- Occupancy (measurement of human resources sufficiency in relation to volumes handled)

Only through the introduction of proper Customer Service Management is it possible to understand the needs and desires of customers to provide them with satisfying and high customer retention experiences.



## Appendix 1 GRI Standards

The following table presents the sustainability topics considered material for Unidata related to the topics defined by the *GRI Su-*

*stainability Reporting Standards*, which were reported within the DNF.

GRI-Standards		Chapters	Par
<b>GRI 102: General Standard Disclosure</b>			
<b>ORGANISATION PROFILE</b>			
102-1	Name of organisation	THE COMPANY AND GOVERNANCE	2.1
102-2	Activities performed, brands, products and services	THE COMPANY AND GOVERNANCE	2.1
102-3	Headquarters Location	THE COMPANY AND GOVERNANCE	2.1
102-4	Location of operations	THE COMPANY AND GOVERNANCE	2.1
102-5	Proprietary set-up	THE COMPANY AND GOVERNANCE	2.1-2.3
102-6	Markets served	THE COMPANY AND GOVERNANCE	2.1
102-7	Size of the organisation	THE COMPANY AND GOVERNANCE	2.1-2.3
102-8	Information on employees and other workers	THE SOCIAL	4.3
102-9	Supply Chain Description	THE SOCIAL	4.4
		METHODOLOGICAL PREMISE	
102-10	Cambiamenti significativi dell'organizzazione e della sua catena di fornitura	LA SOSTENIBILITÀ	1.2
		THE COMPANY AND GOVERNANCE	2.1
102-11	Precautionary principle or approach	THE COMPANY AND GOVERNANCE	2.4
		ENVIRONMENT	3.3-3.6
102-12	External Initiatives	THE SOCIAL	4.1
<b>STRATEGY</b>			
102-14	Statement by the main decision-maker	LETTER TO STAKEHOLDERS	
		THE COMPANY AND GOVERNANCE	2.4
102-15	Key impacts, risks and opportunities	ENVIRONMENT	3.5
		THE SOCIAL	4.2-4.6
<b>ETHICS AND INTEGRITY</b>			
102-16	Values, principles, standards and norms of behaviour	SUSTAINABILITY	1.1-1.2
		THE COMPANY AND GOVERNANCE	2.9
<b>GOVERNANCE</b>			
102-18	Governance structure	THE COMPANY AND GOVERNANCE	2.3
102-20	Responsibility at executive level for economic, environmental, and social issues	ENVIRONMENT	3.2
102-21	Stakeholder consultation on economic, environmental, and social issues	LETTER TO STAKEHOLDERS	
		SUSTAINABILITY	1.3

GOVERNANCE			
102-22	Composition of the highest governing body and its committees	THE COMPANY AND GOVERNANCE	2.3
102-23	Presidency of the highest governing body	THE COMPANY AND GOVERNANCE	2.3
102-25	Conflict of interest	THE COMPANY AND GOVERNANCE	2.4
		SUSTAINABILITY	1.5
102-29	Identification and management of economic, environmental, and social impacts	THE COMPANY AND GOVERNANCE	2.4-2.5 2.6-2.7
		ENVIRONMENT	3.1-3.4-3.6
		THE SOCIAL	4.1-4.5
102-30	Effectiveness of risk management processes	THE COMPANY AND GOVERNANCE	2.4-2.8
102-31	Review of economic, environmental, and social issues	METHODOLOGICAL PREMISE	
102-32	Indicate which committee or position verifies and approves the sustainability report	METHODOLOGICAL PREMISE	

STAKEHOLDER ENGAGEMENT			
102-40	Group Stakeholders	SUSTAINABILITY	1.3
102-42	Stakeholder identification and selection process	THE SOCIAL	4.4
102-43	Approach to stakeholder engagement	SUSTAINABILITY	1.5
102-44	Themes emerging from stakeholder engagement	SUSTAINABILITY	1.5

PROCESSO DI REPORTING			
102-46	Defining the contents of the sustainability report and subject-related limits	METHODOLOGICAL PREMISE	
		SUSTAINABILITY	1.5
102-47	List of material topics	SUSTAINABILITY	1.5
102-50	Reported period	METHODOLOGICAL PREMISE	
102-52	Periodicity of reporting	METHODOLOGICAL PREMISE	
		LETTER TO STAKEHOLDERS	
102-53	Contact for enquiries regarding the report	For further information on this document, please contact Paolo Bianchi (p.bianchi@unidata.it)	
102-54	GRI Standard Compliance Statement	METHODOLOGICAL PREMISE	
102-55	GRI Index	APPENDIX GRI STANDARDS	

#### GRI 103: Approach to Topic Management

103-1	Approach to theme management	THE COMPANY AND GOVERNANCE	2.4-2.6 2.7-2.8
103-2	Approach to theme management	ENVIRONMENT	3.1
103-3	Approach to theme management	THE SOCIAL	4.1-4.5

**GRI 200: Specific Standard Disclosures - Economic Category -****ECONOMIC PERFORMANCE - GRI 201**

<b>201-1</b>	Direct economic value generated and distributed	THE COMPANY AND GOVERNANCE	2.5
--------------	---	----------------------------	-----

**INDIRECT ECONOMIC IMPACTS - GRI 203**

<b>203-1</b>	Development and impact of investments in infrastructure and services provided	THE COMPANY AND GOVERNANCE	2.6-2.7
--------------	---	----------------------------	---------

**ANTI-CORRUPTION - GRI 205**

<b>205-2</b>	Communication and training on anti-corruption policies and procedures	During the year 2021, there were no legal actions for anti-competitive behaviour, antitrust and single-policy practices.	
--------------	---	--	--

**ANTI-COMPETITIVE BEHAVIOUR - GRI 206**

<b>206-1</b>	Legal actions for anti-competitive behaviour, antitrust, and monopolistic practices	During the year 2021, there were no legal actions for anti-competitive behaviour, antitrust and single-policy practices.	
--------------	---	--	--

**GRI 300: Specific Standard Disclosure - Environmental Category -****ENERGY- GRI 302**

<b>302-1</b>	Energy consumed within the organisation	ENVIRONMENT	3.4
<b>302-2</b>	Energy consumed outside the organisation	ENVIRONMENT	3.4
<b>302-3</b>	Intensity energy	ENVIRONMENT	3.4
<b>302-4</b>	Reducing energy consumption	ENVIRONMENT	3.4

**EMISSIONS - GRI 305**

<b>305-1</b>	Direct greenhouse gas emissions (Scope 1)	ENVIRONMENT	3.4
<b>305-2</b>	Indirect greenhouse gas emissions (Scope 2)	ENVIRONMENT	3.4

**ENVIRONMENTAL ASSESSMENT OF SUPPLIERS - GRI 308**

<b>308-1</b>	New suppliers assessed using environmental criteria	ENVIRONMENT THE COMPANY AND GOVERNANCE	3.3-3.4 2.2
--------------	---	---	----------------

**GRI 400: Specific Standard Disclosure - Social Category -****EMPLOYMENT - GRI 401**

<b>401-1</b>	New recruitments and turnover	THE SOCIAL	4.3
--------------	-------------------------------	------------	-----

**HEALTH AND SAFETY OF WORKERS - GRI 403**

<b>403-1</b>	Worker representation in formal health and safety contexts	THE SOCIAL	4.3
<b>403-2</b>	Types of accidents and rates of accidents at work, sickness, lost working days, absenteeism, and total number of deaths	THE SOCIAL	4.3
<b>403-5</b>	Worker training in occupational health and safety	THE SOCIAL	4.3

<b>DIVERSITY AND EQUAL OPPORTUNITIES - GRI 405</b>			
<b>405-1</b>	Diversity of governing bodies and employees	THE SOCIAL	4.3
		THE SOCIETY	2.3
<b>NON-DISCRIMINATION - GRI 406</b>			
<b>406-1</b>	Incidents of discrimination and corrective action taken	During the year 2021, no incidents of discrimination occurred within the company.	
<b>LOCAL COMMUNITIES - GRI 413</b>			
<b>413-1</b>	Activities involving local community involvement, impact assessments and development programmes	THE SOCIAL	4.1
<b>SOCIAL EVALUATION OF SUPPLIERS - GRI 414</b>			
<b>414-1</b>	New suppliers assessed using social criteria	THE SOCIAL	4.4
<b>CUSTOMER PRIVACY - GRI 418</b>			
<b>418-1</b>	Documented complaints about privacy breaches and loss of customer data	THE COMPANY AND GOVERNANCE	2.9
<b>SOCIO-ECONOMIC COMPLIANCE - GRI 419</b>			
<b>419-1</b>	Non-compliance with social and economic laws and regulations	During the year 2021, there were no significant cases of non-compliance and sanctions with respect to the violation of laws and regulations in the economic and social sphere.	



## Appendix 2 Index of Tables and Figures

INDEX TABLES		
<b>Table 1</b>	Unidata Stakeholders	17
<b>Table 2</b>	ESG Themes	20
<b>Table 3</b>	ESG risks	21
<b>Table 4</b>	Breakdown of actions	32
<b>Table 5</b>	Unidata shareholders	32
<b>Table 6</b>	Composition of Unidata's Board of Directors	33
<b>Table 7</b>	Composition of Unidata's Board of Statutory Auditors	34
<b>Table 8</b>	Management Composition of Unidata	35
<b>Table 9</b>	Classification of identified remediations	31
<b>Table 10</b>	Unidata's Value Added Income Statement as at 31 December 2021	46
<b>Table 11</b>	2022/2021 comparison of the number of customers	46
<b>Table 12</b>	2022/2021 comparison of monthly ARPU	47
<b>Table 13</b>	Building Units to be reached in 2023-2024	52
<b>Table 14</b>	Grey areas to be cabled by the end of 2023	53
<b>Table 15</b>	Statistics on service quality	55
<b>Table 16</b>	Composition of Unidata's car fleet	73
<b>Table 17</b>	Unidata consumption from non-renewable sources	73
<b>Table 18</b>	Unidata consumption from renewable sources	74
<b>Table 19</b>	Direct GHG Emissions	75
<b>Table 20</b>	Indirect GHG emissions	75
<b>Table 21</b>	Unidata's board composition	91
<b>Table 22</b>	Gender Diversity in Unidata	91
<b>Table 23</b>	Average age of Unidata employees	91
<b>Table 24</b>	Incoming and outgoing turnover	92
<b>Table 25</b>	Breakdown by gender and classification	93
<b>Table 26</b>	Breakdown by classification and age	93
<b>Table 27</b>	Hours of health and safety training	95
<b>Table 28</b>	Growth of customer base by business area	98
INDEX FIGURES		
<b>Figure 1</b>	Sustainable Development Goals (SDGs)	18
<b>Figure 2</b>	Unidata's SDGs targets	18
<b>Figure 3</b>	Material themes for Unidata	19
<b>Figure 4</b>	Graphic representation of the corporate organisational structure	31
<b>Figure 5</b>	Average Threat Frequency Index for Unidata	39

<b>Figure 6</b>	Average vulnerability index for Unidata	40
<b>Figure 7</b>	Average impact index for Unidata	41
<b>Figure 8</b>	Average risk index for Unidata	42
<b>Figure 9</b>	Risk level by business area at Unidata	42
<b>Figure 10</b>	Risk Management Information Flow	43
<b>Figure 11</b>	Turnover composition chart Business Plan	48
<b>Figure 12</b>	Unidata share performance 16 March 2020 (IPO) - 31 December 2022	49
<b>Figure 13</b>	Fibre optic coverage to 2022	51
<b>Figure 14</b>	Unidata Headquarters Data Centre Structure	60





UNIDATA



762.77

451.91

60.43

38

292.76

38

06

536



Wszystkie dane  
są zgodne z  
ostatnimi danymi  
dostępnymi w  
danej chwili.  
Wszystkie dane  
są zgodne z  
ostatnimi danymi  
dostępnymi w  
danej chwili.